

12345  
**MAKE OUT IN FULL BY MEASURER**  
**Must Be Signed by Fleet Measurer to be Valid**

Applies To All Boats For  
Which Numbers Were  
Issued After 12200

**SNIPE CLASS**  
**INTERNATIONAL RACING ASSOCIATION**  
**MEASUREMENT DATA SHEET**

Use Standard Marking Procedure on this Form:

- (a) When NOT within the tolerance limits allowed, mark an "X" in the margin and state actual measurements.
  - (b) Otherwise, do not write in the measurements of this boat except where specifically called for.
  - (c) Draw a neat circle around number of each paragraph when you have verified or carried out all its details.
1. Measurers must fill in every blank space provided on this sheet. Each dimension shown must be verified by the measurer and if the dimension is not either the maximum or minimum or between the two, the measurer may recommend certificate only if discrepancy is MINOR and clearly shown.
  2. This boat must have been assigned a racing number by the Association which must be carved or burned clearly into the surface of the keel batten directly abaft the center-board trunk. These numbers must be at least 1" high. Unless this is done, the boat cannot receive a Certificate of Measurement.
  3. Official Racing Number of boat on keelson or on a plate if fiberglass boat 12345
  4. Boat's Name TEXAN IV
  5. Full name(s) and address(es) of owner(s) (please print)  
HAROLD L. GILREATH  
RT #  
MARIETTA, GA
  6. Name and charter number of the fleet in which this boat is expected to compete.  
ATLANTA Y.C. 330  
Lake ALABAMA, GA.  
(also home port, bay or lake where it probably will be moored.)

**GENERAL RESTRICTIONS**

7. Boats to be eligible to race in this class must be built to conform in every way to this data sheet. Boats that do not meet all these requirements shall be ineligible to receive a Certificate of Measurement but they must retain their identifying numbers. Such boats cannot take part in any open or closed regattas whatsoever. Owners of such boats shall be ineligible to join S.C.I.R.A. The measurer must notify the Executive Secretary of any boats that cannot pass these requirements, giving the boat number, and name and address of both the builder and owner.
8. Options. Nothing is optional in these plans, specifications or restrictions unless definitely stated as such.  
Boats must be built to plans and offsets. Dimensions shown on this sheet are for checking purposes only and tolerances are to take care of accidental and unavoidable variations from the nominal dimensions and changes in shape which occur as the boat becomes older. The stem must be a smooth curve as shown in the plans.  
The purpose of the restrictions under which Snipe hulls and sails are approved is to insure that, to as great a degree as possible, all hulls and sails have identical racing capability. It is impossible to list every single variation that might turn up in the future, and it is impossible to make any set of restrictions in which, at some future date, someone cannot find what appears to be a legal means of obtaining some racing advantage.  
Any boat or sail having features which are not consistent with this purpose will not be approved and cannot race even though there is no specific restriction preventing the item in question.  
Improvements and changes will be made only when these changes do not obsolete older boats from the standpoint of racing capability or when they can be accomplished by anyone at reasonable expense.  
Approved Options not covered elsewhere:
  1. Self-bailing cockpit: No restriction on method of construction. Bailing equipment must still be carried.
  2. Hiking Straps: No restriction on number or location.
  3. Filler Extension: No restriction on cross section or length.

- (d) Thus, when your examination is completed, every paragraph number will be "circled" (indicating conformity); or will bear an "X" in the margin (something to be re-built or to be submitted to the International Measurement Committee for decision).
4. Boom Vang: No restriction on type. May be used at any time.
  5. Cleats for Jib Sheets or Mainsail Sheets: No restriction on number, type, or location.
  6. Jib Fairleads: Any type or location permitted.
  7. Mainsheet Bridle: Any type or location permitted. May be adjusted while racing.
  8. Attachment of Jib Tack: Any method permissible. May be adjusted while racing.
  9. Mainsail Clew Outhaul: Any type permitted. May be adjusted while racing.
  10. Sliding Goosenecks: May be on track or in slot in mast. May be swiveling and may incorporate roller reefing gear. Must have some means to prevent downward movement beyond position giving maximum legal length of luff. The tack of the sail shall be located so that the bolt rope does not deviate appreciably from a straight line.
  11. In countries where Styrofoam or equivalent material cannot be secured, the use of flotation bags will be permitted. At least two bags must be used and be of approximately equal capacity. Twice as much flotation must be provided as is required with Styrofoam.
  9. Boats must be measured by officially appointed or elected Fleet Measurers. No Certificate shall be acceptable unless recommended and signed by such a Measurer. See "Instructions for Fleet Measurers" in the Rule Book.

**HULL**

10. Check hull materials below. Where O.K., use check-mark. Give actual dimension only when found different.
  - Molded depth of frames - - - - - (2 1/4") ✓
  - Frames must be located within 1/4" of station lines. ✓
  - Thickness of frames - - - - - (3/4") ✓
  - (Frames may be made of fir exterior plywood in one piece or in four pieces joined by suitable gussets at the chine and floor timbers at the keel.) ✓
  - Thickness of gussets at chine - - - - - (3/4") ✓
  - (Gussets at chine may be made of 1/4" fir exterior plywood if double, and 1/2" fir exterior plywood if single.) No gussets required if the frames are made in one piece. ✓
  - Dimensions of chine pieces - - - - - (3/4" x 1 1/2") ✓
  - Dimensions of clamps - - - - - (3/4" x 1 1/2") ✓
  - Clamps shall be bonded to the side of the boat at the sheer on plywood hulls. They may be installed in this manner on fiberglass or planked hulls or may be omitted entirely.
  - Thickness of side planking - - - - - (3/8") 3/8 PLY ✓
  - Thickness of bottom planking - - - - - (3/8") 3/8 PLY ✓
  - Thickness of sides of trunk: 3/8" minimum, 1/2" recommended 3/8" PLY ✓
  - Thickness of transom (estimate acceptable) (3/4") ✓
  - A 3/4" exterior plywood transom may be used.
  - Thickness of deck - - - - - (1/2") 1/2 PLY ✓
  - Deck may be made of 1/4" exterior plywood.
  - Dimensions of transom cheek pieces - (3/4" x 2 1/4") ✓
  - Thickness of stern knee - - - - - (3/4") NONE ✓
  - Width and thickness of keel batten - (3/4" x 5") 3/4 x 8 ✓
  - Width and thickness of keel - - - - - (3/4" x 4") ✓
  - Dimensions of deck beams (plywood or spr.) - - - - - (3/4" x 2") 3/4 x 3 ✓

11. Planking. Must be at least  $\frac{3}{4}$ " thick throughout the sides and bottom of the hull. Double or triple planking may be used but the total thickness must be  $\frac{3}{4}$ ". For boats in countries other than the United States where suitable light-weight wood for planking is not readily available, the use of  $\frac{1}{2}$ " mahogany planking (unit weight of 61.85 pounds per cubic inch or greater) will be allowed. Upon appeal by the National Secretary made to the International Rules Committee. When the  $\frac{1}{2}$  inch mahogany planking is used, it will also be required that the frames, keel, keel batten, stern, and centerboard trunk be made of mahogany, and to dimensions as shown in the Measurement Data Sheet, except as altered in this paragraph. The thickness of the keel will be  $\frac{1}{2}$  inch and the thickness of the keel batten will be 1 inch. In any case, uniform thickness will be required throughout the sides and bottom of the hull. Canvas or other filler between layers shall not be considered as part of this dimension. Transom must be  $\frac{3}{4}$ " thick.
12. Hull Structure. The entire hull must be built like the plans and specifications and restrictions. Kind of wood used is optional but the 425 pound minimum weight limit must be observed. The materials specified in plans are best suited.
13. No tapered timbers, frames, etc., permitted.
14. The dimensions as given above are minimum for all sizes. They are the sizes specified in plans.
15. Keel must be at least 4" wide on flat under surface from stern to frame 2. It must be at least 2" wide at frame 1.
16. Holes cut in any part of frame structure for lightening hull are forbidden.
17. Snipe hulls may also be built of fiberglass or plywood. The specifications and restrictions on the use of these materials are listed in a supplement to the Measurement data sheet and may be obtained from the Executive Secretary.

#### DECK

19. Forward deck. This must extend the full width of the boat to a point at least 6' 8" abaft of the bow. Maximum crown of deck not to exceed 5". The top of the sprayboards must be at least 2" vertically above the deck for not less than 2' of their respective lengths. Maximum projection of deck or sheer molding beyond sheer is  $1\frac{1}{4}$ ".
20. After deck may not be less than 18" in length.
21. How many deck beams used? 9 (5+4)  
(16 minimum including side deck beams)

#### COCKPIT

22. Greatest length of cockpit 65 1/2". Greatest width 25 1/2". (The cockpit as designated in plans is recommended 2' x 6'). Boats having cockpits more than 36" in width cannot receive a measurement certificate. If the cockpit has a radius, the width is measured from the point of tangency of the radius and the deck. Cockpit corners may be square or rounded to any desired radius.
23. Floorboards may be reasonably spaced, must be adequate for their purpose and must approximate the cockpit opening in coverage. Must not be over  $\frac{3}{4}$ " thick. May be of plywood. Floorboards must be installed on the frames or floorboard supports, unless made of plywood and bonded to the bottom of a fiberglass hull. The area of the bottom covered by the floorboards shall be of at least the width and length of the cockpit, and the area of the floorboards shall be at least 60% of the area they cover.

#### CENTER-BOARD

24. Check type on this boat. Dagger X Pivoted     .
25. Verify dimensions with sketch. No other shapes permitted. Slot in dagger board shall not be more than  $1\frac{1}{2}$ " longer than the width of board. Boards must be of uniform thickness except within 1" of edges which may be tapered off. Dagger board may be cut out for lightness either radius or straight cut. (See plans.) The top of the front leg of a daggerboard may be sloped back at an angle not greater than 45 degrees, starting at a point 12" above the centerpunch mark  $3\frac{3}{4}$ " from the bottom of the board.
26. A dagger board cannot be used in the slot of a pivoted center-board.
27. No center-board of either type shall exceed 80 lbs. in weight. The dimensions for boards as given on the sketch on the back of this sheet must be adhered to. All types of center-boards must be made of one single kind of metal. There shall be no inserts or other means of changing the distribution of the weight. Aluminum boards may be made of any hard aluminum alloy. 6061T6 or its equivalent is recommended. Minimum thickness of aluminum boards  $\frac{3}{4}$ ". Minimum thickness of steel or bronze boards  $3/16$ ". Recommended minimum thicknesses are  $5/16$ " for aluminum and  $\frac{1}{4}$ " for steel or bronze. Only one center-board shall be permitted to be measured. Only steel, bronze, and aluminum boards are approved.

#### RUDDER

28. See that rudder is substantially made and properly doweled.

May be made of  $\frac{3}{4}$ " exterior plywood. See that tiller is strong and attached directly to rudder head.

29. Thickness above waterline 3/4" ( $\frac{3}{4}$ " minimum).
30. The length from underside of keel to bottom of rudder, measured diagonally across should be  $1'-11\frac{1}{2}"$  (allowance 1" plus or minus).
31. The width of blade below waterline must be not less than 9" at any point. This measurement is taken across rudder at approximately right angles to its leading edge.
32. Metal rudder blades are prohibited. While pivoting rudders are desirable because of purely local conditions, they may be used for local point score races only. They may not be used in any regattas or championships. Tillers must be direct connected and all above the aft deck. Rudder must at all times be submerged as shown in the plans. Vertical adjustments or changes in angle are not permitted. Rudder must be attached to the transom and as close to the transom as conveniently possible with 1" maximum clearance.

#### MAST, BOOM AND RIGGING

33. Maximum allowable length of mast from top of mast (not counting wind indicators) to top of sheer shall be 20'-3". Only one mast may be measured.
34. The minimum allowable length from sheer molding shall not be under 20'-1".
35. The center line of the mast shall be located 60 to 71 inches aft of the stem. This measurement shall be taken to the mast step. Where the mast is stepped on the keel, the hole in the deck where the mast goes through the deck may be of any size and location.
36. Mast may be stepped on deck provided height above sheer is correct. Rotating masts and any means of artificially inducing bending prohibited.
37. The mast must be at least  $1\frac{1}{2}$ " athwartships at top.
38. If mast is made of wood, it must be at least 2" athwartships and 3" fore and aft at deck. If mast is round (not streamlined), the dimension at deck must be not less than  $2\frac{1}{2}$ " in diameter. Give dimension of this mast 2 1/2" AL.
39. Give shape of mast. Square      Round      Pear shaped
40. Is mast hollow or solid? Hollow In hollow wooden masts the walls must be at least  $\frac{3}{8}$ " thick. Verify if in serious doubt.
41. Measure distance from sheer to the intersection of the jib stay with surface of the mast... See sketch on measurement drawing for method of determining the intersection. Dimension may be 15" maximum, 14'-11" minimum. Shroud intersection must be within 2" above jib stay intersection or 4" below.
42. Halliards must be used, and the top of main halliard must lie not less than 1" from top of mast. The luff of the mainsail shall not be stretched beyond 16'-7" in length while racing. To permit checking this, bands 1" wide shall be painted around the mast in a color to contrast with the color of the mast. The center lines of the bands shall be located as follows:
1. To coincide with the center of the grommet in the headboard of the sail when the sail is hoisted as far as possible.
  2. Six inches and twelve inches below the top band.
  3. Sixteen feet seven inches below each of the above bands. The sail may be set at any height desired as long as the sail luff is not stretched so that the distance between grommets in the headboard and tack is greater than the distance between corresponding bands.
43. Length of boom shall be 8'-8" maximum, 8'-6" minimum, measured from aft side of mast. Only one boom may be measured. The foot of the mainsail shall not be stretched beyond 8'-3" in length while racing. To permit checking this, a band 1" wide shall be painted on the bottom in a color to contrast with the boom, the center line of the band being 8'-3" from the center line of the grommet in the tack of the sail when the tack is attached to the gooseneck.
44. The maximum depth of boom no matter what type or material shall not exceed 4" at any point, minimum 2". Check      The boom shall not be in excess of 3" wide at any point. If a plank boom is used, it must be at least  $\frac{3}{4}$ " thick throughout. If slotted boom is used, it shall not exceed 4" in depth including the wood forming the slot. Round booms must have a minimum diameter of 2". Any type boom must equal stiffness of 2" diameter solid spruce boom.
45. Aluminum extrusions may be used for masts and booms. Currently approved sections are as follows:
- (1) An extrusion made in the United States, measuring 2.65" fore and aft, and 1.75" athwartship, with a wall thickness of .085". When used as a mast, this section must use diamond stays below the shroud anchorages with a spreader having an overall length of at least 15".
  - (2) The Ian Proctor extrusion, having a fore and aft dimension of 2.70"; an athwartship dimension of 2.19"; a varying wall thickness; and a weight of .796 lbs. per foot. Swinging spreaders at least 17" long must be used between the mast

and the sidestays when used as a mast.

- (3) The Ian Proctor extrusion having a fore and aft dimension of 3.0825"; an athwartship dimension of 2.375"; a varying wall thickness; and a weight of .938 lbs. per foot. This section is tentatively approved for a mast without spreaders.
46. Boom and mast may be slotted to take sail bolt rope provided dimensions are met.
47. No restrictions on whisker pole length or its location.
48. Shroud anchorages must be not more than 4" in from the edge of deck, not counting sheer molding. Anchorages of jib stay and shrouds may be under deck and locations and length of all stays must be incapable of change during a race. The use of elastic light line between the shrouds and the mast is permitted.
49. All boats must have regulation jib stay and two side shrouds as per plans and restrictions. No back stay may be used.
50. Side shrouds and jib stay must be as shown in plans (within allowable variations). All other rigging optional. So-called streamlined rigging not permitted. Running rigging optional. Double jib stays not permitted. Mast rakers not permitted. If, in the opinion of the Measurer, the rig shall be considered unsound, weak or unseaworthy, the Measurer must not recommend a Measurement Certificate. Changes must not be made after the Certificate is issued, unless the owner has Measurer recheck the rig.

#### WEIGHT LIMIT

51. THE BOAT COMPLETE MUST WEIGH 425 POUNDS MINIMUM. THIS WEIGHT DOES NOT INCLUDE ANCHOR, PADDLE, LIFE PRESERVERS, BAILING EQUIPMENT (unless permanently attached), SAILS, SHEETS, OR ANY OTHER LOOSE GEAR. BOATS THAT DO NOT MEET THIS WEIGHT LIMIT MUST HAVE WEIGHT PERMANENTLY ADDED BEFORE THEY CAN BE GIVEN MEASUREMENT CERTIFICATES.

52. The weight of this boat as outlined above is 425 lbs.

Weight of anchor (minimum weight 4 lbs.) \_\_\_\_\_ lbs.

53. All boats must be weighed before issuing a measurement certificate and must be re-weighed at the start of each season. The weight and the amount of ballast, if any, shall be noted on the membership card.

54. The Measurer shall either witness the weighing of the boat or require the owner to furnish a weight certificate signed by at least two witnesses and the owner as well as the owner of the scales, that the boat complete weighs 425 pounds or more. A boat that weighs less will not be issued a Certificate under any conditions. Ballast, up to 10 pounds, may be permanently added immediately under and attached to the deck. If the boat's centerboard weighs less than 80 lbs., ballast up to an amount equal to the difference between the weight of the board and 80 lbs. may be in any location. All ballast must be bolted, screwed, or bonded securely to the structure of the boat.

55. Weight certificates from builders will not be accepted.

56. The weight not to include any trailer, truck, packing cases, crates or cradles, or weights other than the hull, rigging, spars, and rudder.

57. If this boat has a weight certificate, it must be attached to this Measurement Data Sheet and sent to the class Secretary. A duplicate weight certificate may be retained by the owner.

#### MISCELLANEOUS

58. Measurer must notify the owner of the following essential requirements: Boat must carry two life preservers or buoyant cushions. Small inflatable pocket-type life preservers are not considered adequate. They must be carried at all times—regardless of whether the boat is racing or not! Suitable paddle (or oar), and adequate bailing equipment must be carried. Electric bilge pumps are approved. No dead ballast may be carried. Anchor of not less than 4 lbs. must be carried with 25' suitable line.

59. There shall be no advertising matter whatever on the outside of any boat or sails. Any boat infringing this ruling shall be subject to loss of measurement certificate. Measurers shall not issue a certificate to any such boat.

60. Give name and address of builder of boat \_\_\_\_\_

HAROLD GILBERT  
MARLETTA GA

61. Sliding seats, hiking boards, trapeze rigs, and other artificial methods of supporting the skipper's or crew's weight to balance the boat are prohibited. This does not prevent the use of hiking straps or any kind of line or cord attached to the boat within 8" of the top of the deck. It is permissible for the crew to hold on to the side stays.

#### SAILS

62. Any means of artificially changing the shape or length of the foot, leech or luff of either jib or mainsail is prohibited.
63. No extra battens or other means of artificially stiffening the

leech of either sail shall be used.

64. All boats in races must carry their own sails with the proper numbers attached thereto. In sanctioned races where the boats are borrowed, a borrower must use his own regular racing sails.

65. Material: Any type of woven fabric may be used as long as it has a minimum weight of 3 ounces per square yard (note: most weights for sail material are given in ounces per lineal yard and in varying widths, which are generally around 28"). A transparent window of non-woven material may be used in the jib if desired. Maximum area, one square foot.

66. The dimensions for sails as given are for maximum measurements. Sails over dimensions on any side are not allowable. A new sail must not be approved which, in the Measurer's opinion, will not be within the specified limits after "breaking-in." Sails are subject to remeasurement and to cancellation of approval at any time. They must be measured at the start of each season and so marked. Disregard roaches; use straightline measurements, taken to the center of the main-sail headboard hole and in all other instances to the centers of the grommets normally located just inside the roping at the corners of sails. The supplemental drawing on limiting sail dimensions shall be used when it appears that an effort has been made to make an over-sized sail. Grommet locations may be averaged. A light pull of about 3 lbs. shall be applied to the corner which is opposite the side being measured. The luff of the jib shall be subjected to a direct-line pull of 16 lbs., while it is being measured; and leeches shall be subjected to a direct-line pull of 8 lbs. Mainsails should be measured with battens in place.

		Allowance	
		Over	Under
Leech	(17'-6")	None	No limit

Mainsail luff and foot need not be measured. A limiting dimension of 16'7" on the luff and 8'-3" on the foot will be checked on the mast and boom when the boat is racing. The maximum dimension across the sail from the midpoint of the luff to the midpoint of the leech is 5'10 1/2". Determine the midpoint of the luff by folding the sail until the center of the grommet in the headboard coincides with the center of the grommet at the tack. Determine the center of the leech using the headboard grommet and the grommet at the clew. Spread the sail out flat, smoothing out the wrinkles and measure between the points. No tension need be applied unless necessary to remove wrinkles.

68. Battens in mainsail may be shorter but not longer than: (Pockets not over 1 1/2" longer than batten)

Top batten	(18")
Center batten	(27")
Lower batten	(24")

69. The headboard in mainsail shall not exceed 6" measured perpendicular to the luff.

70. Racing numbers shall be at least 10" in height and on both sides of the mainsail. The class insignia must also be on both sides of the mainsail before sail is approved. Letters to designate the nation under which the boat is registered may be used if desired. Insignia denoting honor awards consisting of chevrons may be worn. See Para. 70 in the Rule Book for details.

		Allowance	
		Over	Under
Foot	(6'-4")	1" (note)	No limit
Roach on Foot	(5")	None	No limit
Luff	(12'-3")	None	No limit
Leech	(11'-6")	None	No limit

72. Genoa jibs must have all snap hooks properly attached to stay when racing. May be sheeted inside or outside shrouds. No battens whatever allowed in jib. No headboard permitted in genoa jib. Jibs must have at least five hooks, one near each end of the luff and the other three evenly spaced between. All jibs must have a wire in the luff to prevent pulling of the jib beyond the dimensions given in Paragraph 71 above.

73. Loose footing any mainsail prohibited. Spinnakers not permitted.

74. Measurer shall mark the tack of each approved sail with the date, fleet number, and his initials before it may be used in any race.

Additional copies of this blank are available to interested parties and may be had upon request from the Class Secretary.

There are no royalties to pay on Snipes, sails, etc., except for \$25.00 for each fiberglass hull. Once a number is assigned to a Snipe, it remains with it forever.



# SNIPE SAILS - ADDITIONAL LIMITING DIMENSIONS

1960

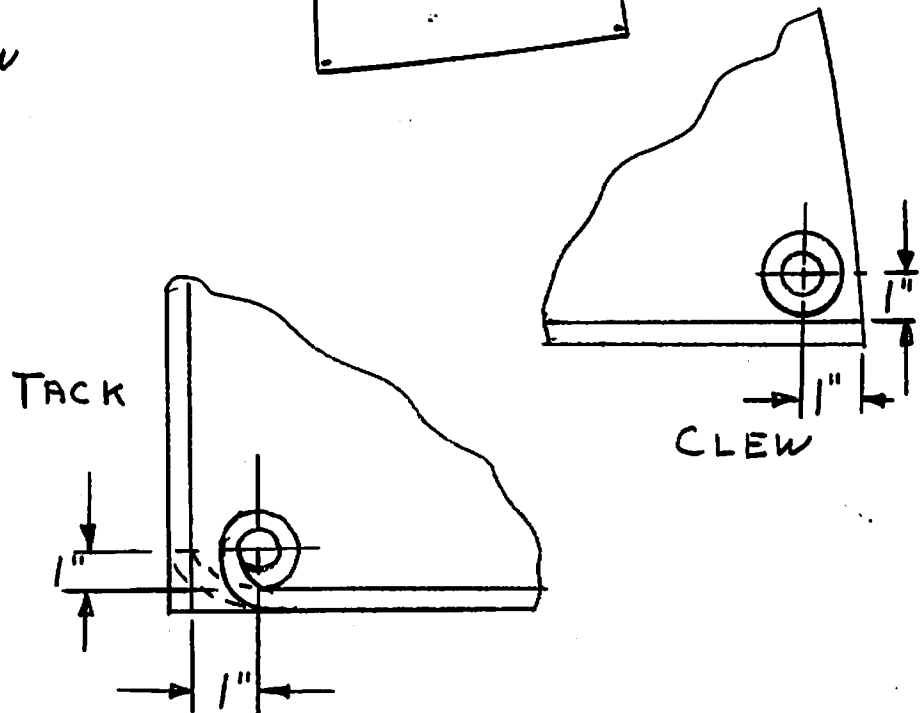
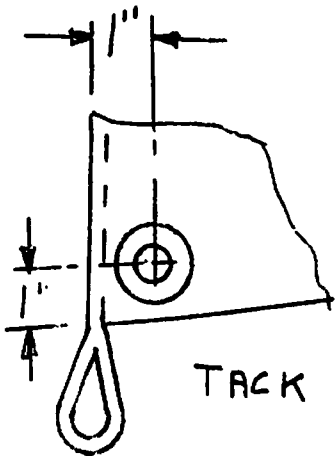
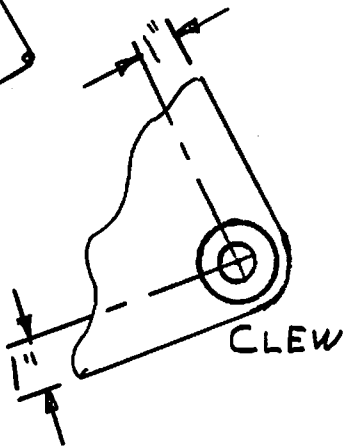
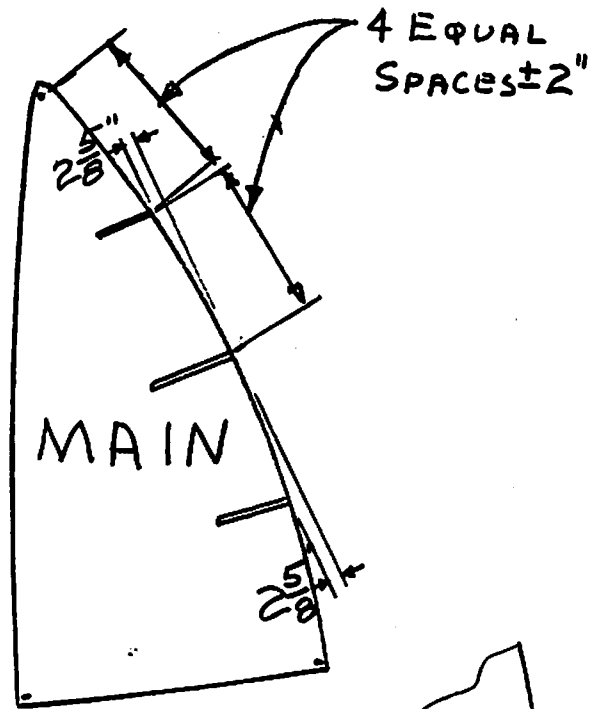
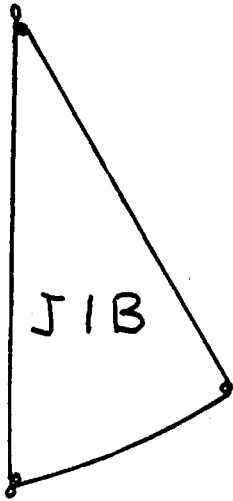
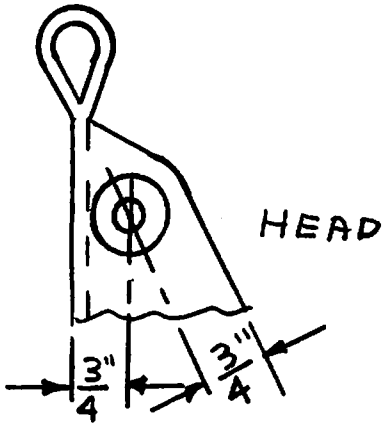
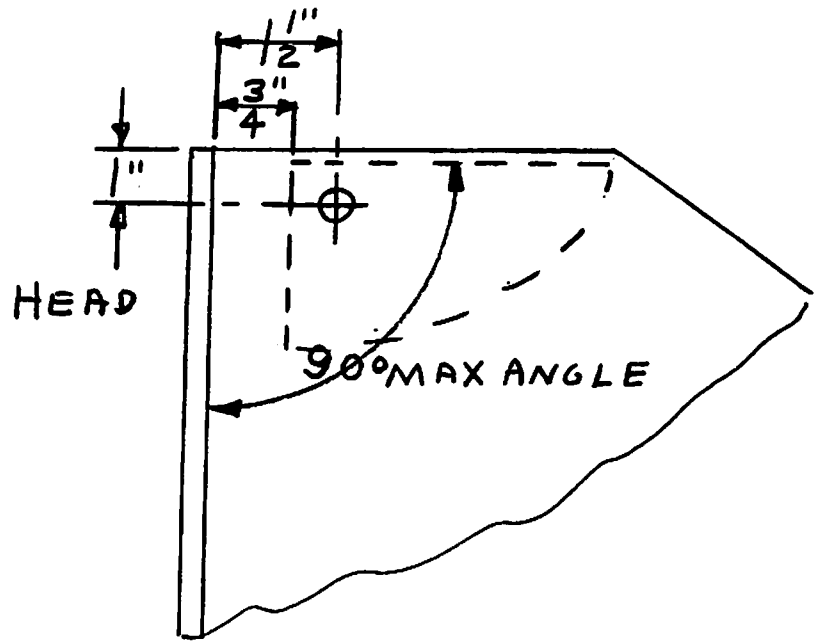

## SUPPLEMENT TO THE MEASUREMENT DATA SHEET FOR THE CONSTRUCTION OF FIBERGLAS HULLS

All fiberglass hulls in the United States must be made from a mold which has been made on the master mock-up owned by the SCIRA. In countries other than the United States, other mock-ups may be made, but they must be made in exact accordance with a set of full-scale loft lines which may be purchased from SCIRA. No deviations will be allowed on fiberglass hulls from these loft lines. (Note: The loft lines do not show any sheer molding. Part or all of a sheer molding may be molded with the hull.)

A \$25.00 royalty must be paid to the SCIRA on every fiberglass hull built. Builders will be required to withhold delivery of hulls until this royalty has been paid.

The completed fiberglass hull must conform to the standard weight limitation of 425 pounds. The minimum weight of the bare, trimmed fiberglass hull including the trunk, floorboard supports, mast step, stay anchorages, and  $6\frac{1}{2}$  cubic feet of Styrofoam having a maximum weight of two pounds per cubic foot for flotation shall be 195 pounds.

**MATERIALS:** Cloth, woven roving or mat may be used, with either polyester or epoxy resins. Glass content must be at least 30% by weight.

**FLOTATION:**  $6\frac{1}{2}$  cubic feet of Styrofoam or its equivalent having a density of 2 pounds per cubic foot maximum must be built into the hull.

**CLAMP:** Optional. If used should be laminated in order to not deform hull.

**TOLERANCE:** The tolerance on the width of the sheer is: plus  $1/4$  inch, minus  $1/8$  inch, with the additional allowance of plus or minus  $1/2$  inch at any two stations. The sheer height must be as shown on the loft lines with minimum deviation.

The thickness of the hull must be uniform except where reinforced locally such as at the keel, the chine, the stem, the mast step, and where the stay anchorages and rudder gudgeons are attached.

Floorboard supports must be bonded to the bottom. They may be made of fiberglass or wood. If desired, plywood floorboards may be bonded directly to the bottom of the boat, omitting floorboard supports. A fiberglass and styrofoam sandwich floor structure may be used.

**DECKS:** The deck may be plywood as specified in the measurement data sheet, or it may be fiberglass. In general, a fiberglass deck will require some type of double surface and core construction to secure adequate stiffness.

In order to insure compliance with all restrictions and specifications, each builder's method of construction must be approved by the Rules Committee.

## SUPPLEMENT TO THE MEASUREMENT DATA SHEET FOR THE CONSTRUCTION OF PLYWOOD HULLS

**BOTTOM AND SIDES:** Minimum thickness  $3/8$  inch or nearest metric equivalent. The weight of the plywood used must be at least one pound, two and one-half ounces per square foot. If  $3/8$  material is used throughout, fiberglass or other covering material must be used.

**KEEL:** Same thickness as bottom --  $3/8$  inch or  $1/2$  inch (whichever used) x 4 inches wide. May be beveled so plywood overlaps it and is in turn beveled.

**KEEL BATTEN:** 1 inch thick. 7 inches wide.  $3/4$ "

**CHINE PIECES:** 1 by 2 inches. The top of the chine pieces may be beveled to be parallel to the bottom.

**CLAMP:** The clamp will be on the sheer next to the sides.

**FLOTATION:** Three cubic feet of Styrofoam must be installed in the hull. Restrictions for frames, deck beams, transom, trunk, deck, and etc. are not changed.

**MINIMUM HULL WEIGHT:** The hull including the centerboard trunk, mast-step, stay anchorages, and flotation, but not including the deck, deck beams, or cockpit framing shall weigh at least 195 pounds. Fiberglass or other covering material may be included in this weight.

**FOR EXPERIENCED PROFESSIONAL BUILDERS:** Optional methods of construction may be approved on application. One option presently approved permits use of fewer cross members but more longitudinal members, assembled with adequate tooling.