

SNIPE CLASS RACING ASSOCIATION

MEASUREMENT DATA SHEET Sheet I- revised January 2009 For boats built after January 1, 2009

HULL NUMBER..... POR 28206 BUILDER..... Person
 MODEL..... Person YEAR..... 1991
 OWNER..... Daniel Santana COUNTRY..... Portugal

BARE HULL COMPLETE from certified mould INCOMPLETE
 HULL MATERIAL: WOOD FIBERGLASS *make note of*
 DECK MATERIAL: WOOD FIBERGLASS *incomplete items*

| | | | |
|--|-------------------------------------|--|-------------------------------------|
| HULL WEIGHT (MIN 125KG) | <input checked="" type="checkbox"/> | MAST LENGTH (6499MM) | <input checked="" type="checkbox"/> |
| TOTAL WEIGHT (172.8KG) | <input checked="" type="checkbox"/> | Limiting bands & pin | <input checked="" type="checkbox"/> |
| BALLAST (MAX 15KG mark below) | <input checked="" type="checkbox"/> | BOOM LENGTH (2642MM from aft edge of mast) | <input checked="" type="checkbox"/> |
| MOI | <input checked="" type="checkbox"/> | Limiting bands | <input checked="" type="checkbox"/> |
| JIB FITTING (279-330 dist. from pt 0) | <input checked="" type="checkbox"/> | POLE LENGTH (2642MM) | <input checked="" type="checkbox"/> |
| SHROUDS (1778-1981mm dist. from pt. 0) | <input checked="" type="checkbox"/> | RUDDER DIMENSIONS | <input checked="" type="checkbox"/> |
| UPPER GUDGEON (410+/-3MM) | <input type="checkbox"/> | RUDDER WEIGHT (2.72kg) | <input checked="" type="checkbox"/> |
| LOWER GUDGEON (155 +/-3MM) | <input type="checkbox"/> | Fits the Transom (Y/N) | <input checked="" type="checkbox"/> |
| MAST HOLE (1494mm dist. from pt. 0) | <input checked="" type="checkbox"/> | CENTERBOARD DIMENSIONS | <input checked="" type="checkbox"/> |
| TRUNK HEIGHT (310 -0+3MM) | <input checked="" type="checkbox"/> | Band | <input checked="" type="checkbox"/> |
| | | Restraining System & stoppers | <input checked="" type="checkbox"/> |

Mark ballast here

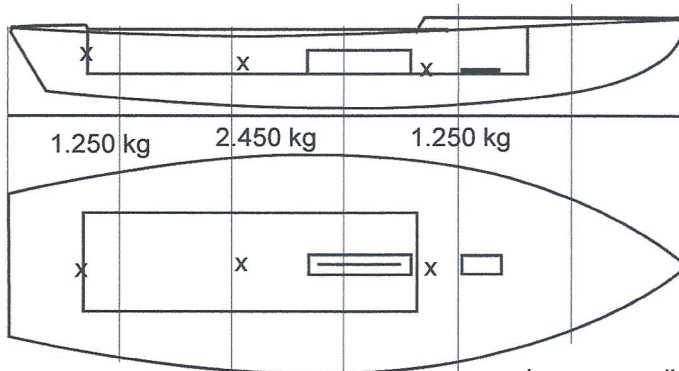

algumas medidas no sistema antigo

DATE MEASURED..... 03/09/2015

MEASURER'S SIGNATURE..... Domingos Borralho

MEASURER'S STAMP..... Pedro Andrade

NOTES: Certificado emitido e entregue em 25/04/2016 (Paulo Sena)

Both pages must be completed and sent to the SCIRA office upon completion of measurement except if hull is from a certified mould.

SCIRA Measurement Check Sheet

To be used with the 80/20 true baseline measurement frame

Owner: Daniel Santana Date: 1991

Hull # 28206 Builder: Person Material: F.G.

Chines Height

| Station | Starboard | Port | Total | Allowable Range | Width | Allowable Range |
|---------|-----------|------|-------|-----------------|-------|-----------------|
| 1 | | | | 838-864 | | 527-540 |
| 2 | | | | 724-749 | | 991-1003 |
| 3 | | | | 673-699 | | 1232-1245 |
| 4 | | | | 680-705 | | 1270-1283 |
| 5 | | | | 762-787 | | 1137-1149 |
| Transom | | | | 902-927 | | 952-965 |

Sheer

| Station | Starboard | Port | Total | Allowable Range | Width | Allowable Range |
|---------|-----------|------|-------|-----------------|-------|-----------------|
| 1 | | | | 1499-1549 | | 895-921 |
| 2 | | | | 1391-1441 | | 346-1372 |
| 3 | | | | 1333-1384 | | 1511-1537 |
| 4 | | | | 1321-1372 | | 1473-1499 |
| 5 | | | | 1321-1372 | | 1270-1295 |
| Transom | | | | 1384-1435 | | 1022-1048 |

Keel

| | Height | Width |
|---------|--------|-------|
| 400mm | | |
| 1 | | |
| 2 | | |
| 3 | | |
| 4 | | |
| 5 | | |
| Transom | | |

Rudder

| | |
|-----------|----------|
| Weight | 2.950 kg |
| 2.72kg | |
| Shape | x |
| Thickness | x |
| Lock | x |
| Keel Ext. | x |

Daggerboard

| | |
|------------|---|
| Bottom | x |
| Shape | x |
| Thickness | x |
| Stripe | x |
| Punch mark | x |
| Tapers | x |

Horizontal Transom Offset 203-229 LOA 4711-4737

Weight 172.800 kg Ballast (lead) 4.950 kg MOI >27.6 27.8

Mast

| | |
|------------------|---|
| Band loc | x |
| Length <6499mm | x |
| Limiting pin | x |
| Sheer mark | x |
| Weight/bal 9.1kg | x |

Boom

| | |
|---------------------|---|
| Band loc 2559mm | x |
| Limiting pin | x |
| Max Length <2642mm | x |
| Pole length <2642mm | x |

Bow

| | |
|---------------------|--|
| Stem height 683-708 | |
| Bow radius | |

Topside Measurements

| | | | |
|---|------|----------------------------|---|
| Aft end of Trunk 2438-2464 from stem | x | Length of daggerboard slot | x |
| Top of trunk parallel to baseline | x | Width of daggerboard slot | x |
| Aft edge of trunk perpendicular to baseline | x | Stem to mast partner >1494 | x |
| Keel to top of trunk 310-313 | ant. | Length of foredeck >1842 | x |
| Shroud fitting to stem 1778-1981 | x | Length of aft deck >457 | x |
| Mast step to sheer (vertical) 390-400 | ant. | Headstay to stem 279-330 | x |

Measurer Domingos Borralho

01 SCIRA
MEASURER
PORTUGAL