

# SNIPE CLASS RACING ASSOCIATION

## MEASUREMENT DATA SHEET FOR CERTIFIED BOATS

Revised February 2019

*This page to be used for all boats. For measurements in Italic refer to the Class Rules*

HULL NUMBER	28281	BUILDER	Persson
MODEL	Persson	YEAR OF MANUFACTURE	1992
OWNER	Bernardo Macedo	COUNTRY	PORTUGAL

BARE HULL	<input type="checkbox"/>	COMPLETE	<input checked="" type="checkbox"/>	INCOMPLETE	<input type="checkbox"/>
HULL MATERIAL: WOOD	<input type="checkbox"/>	FIBERGLASS	<input checked="" type="checkbox"/>	make note of	
DECK MATERIAL: WOOD	<input type="checkbox"/>	FIBERGLASS	<input checked="" type="checkbox"/>	incomplete items	
FROM CERTIFIED MOULD	<input checked="" type="checkbox"/>			filling the cells with <b>NO</b>	

HULL WEIGHT (min 125kg)	<input checked="" type="checkbox"/>	MAST LENGTH (Rules C.9.2, F.3.4)	<input checked="" type="checkbox"/>
TOTAL WEIGHT (min 172.8kg)	174.0 kg	Limiting marks & pin	<input checked="" type="checkbox"/>
CORRECTOR WEIGHTS (max 15kg)	2.0 kg	Corrector weights (max 100gr)	0
MOI	271.03	BOOM LENGTH (max 2642mm)	<input checked="" type="checkbox"/>
Spring set #	<input checked="" type="checkbox"/>	Limiting marks & pin	<input checked="" type="checkbox"/>
JIB FITTING	<input checked="" type="checkbox"/>	POLE LENGTH (max 2642mm)	<input checked="" type="checkbox"/>
(279-330mm hor. From Hull Datum Point)		RUDDER DIMENSIONS	<input checked="" type="checkbox"/>
max 45mm vert. above sheerline)		Weight (min. 2.72kg)	3.10 kg
SHROUDS (1778-1981mm from HDP)	<input checked="" type="checkbox"/>	Corrector weights (Rule C.8.5)	0
MAST HOLE (min 1494-mm from HDP)	<input checked="" type="checkbox"/>	Parallel to transom (tolerance 2mm)	<input checked="" type="checkbox"/>
UPPER GUDGEON (Rule D.2.3)	N/A	DAGGERBOARD DIMENSIONS	<input checked="" type="checkbox"/>
LOWER GUDGEON (Rule D.2.3)	N/A	Band	<input checked="" type="checkbox"/>
GUDGEONS DIAMETER (Rule D.2.3)	N/A	Safety line (max 610mm long)	<input checked="" type="checkbox"/>
		Restraining system (hooks or tablet)	<input checked="" type="checkbox"/>

Insert the **actual** measurement in the cells marked as

Mark corrector weights position and amount below. Data to be copied on the Official Snipe Label

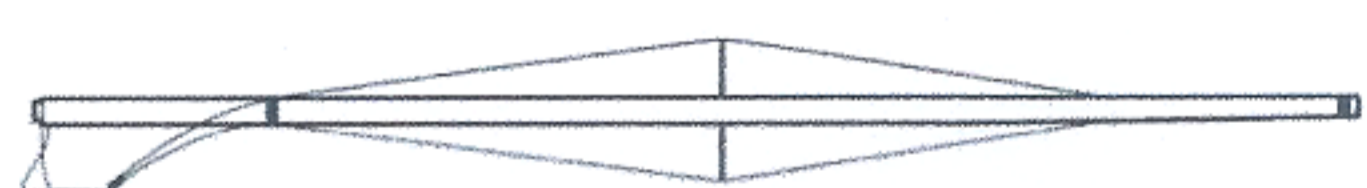
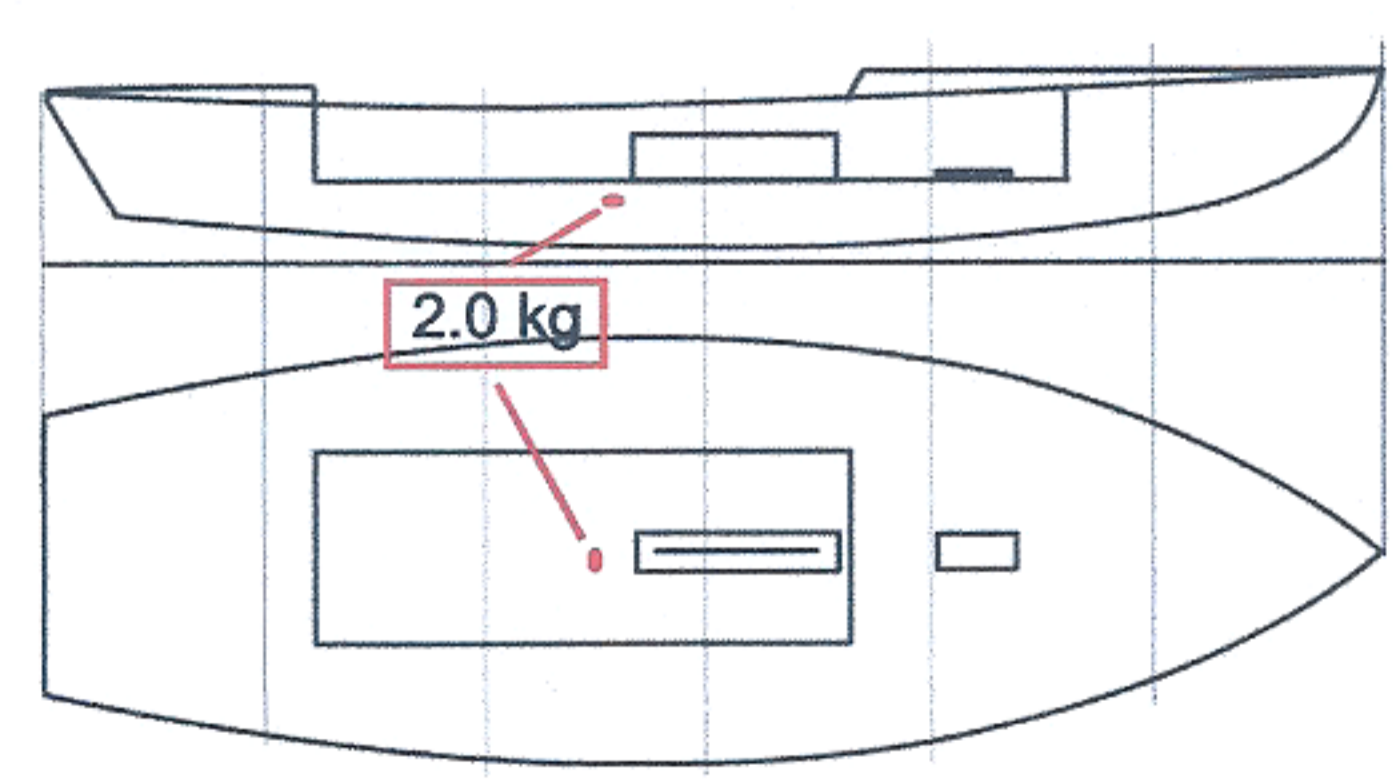

DATE MEASURED 7/5/2022

MEASURER'S STAMP

**01 SCIRA MEASURER PORTUGAL**

MEASURER'S NAME Domingos Borralho

NOTES: NATIONAL SECRETARY : Pedro Andrade

*Pedro Andrade*