

30108 SNIPE CLASS INTERNATIONAL RACING ASSOCIATION

MEASUREMENT DATA SHEET

Sheet G - Revised January 1996
For all boats built after January 1, 1996,
EXCEPT AS NOTED

Use Standard Marking Procedure on this form:

- When NOT within the tolerance limits allowed, mark an "X" in the margin and state actual measurements.
- Otherwise, do not write in the measurements of this boat except where specifically called for.
- Draw a neat circle around the number of each paragraph when you have verified or carried out all its details.
- Thus, when your examination is completed, every paragraph number will be "circled" (indicating conformity); or will bear an "X" in the margin (something to be rebuilt or to be submitted to the International Rules Committee for decision).

****PLEASE PRINT****

1. Measurers must fill in every blank space provided on this sheet. Each dimension shown must be verified by the measurer and if the dimension is not either the maximum or minimum or between the two, the measurer may recommend certificate good for local races only on home built boats, if discrepancy is MINOR and clearly shown. No discrepancies permitted on professionally built boats.

2. This boat must have been assigned a racing number by the Association which must be carved, burned, or molded into the centerboard trunk in an unobscured position. Minimum height of these numbers must be 1/2" (13mm). Unless this is done, the boat cannot receive a Certificate of Measurement. In order to be eligible to race, every boat must have an official decal for the current year, permanently attached to the starboard side just forward of the transom. Decals will be issued by the appropriate secretary for each year that dues are paid.

- Official Racing Number of boat on trunk 30108
- Boat's Name
- Full name(s) and address(es) of owner(s)

TIAGO MARCELINO

Portugal

- Name and charter number of the fleet in which this boat is expected to compete.

General Restrictions

7. Boats to be eligible to race in this class must be built to conform in every way to this data sheet. A boat that does not meet all these requirements shall be ineligible to receive a Certificate of Measurement but it must retain its identifying number. Such boats cannot take part in any open or closed regattas whatsoever. Owners of such boats shall be ineligible to join SCIRA. The measurer must notify the Executive Director of any boats that cannot pass these requirements, giving the boat number, and name and address of both the builder and owner.

8. Options. Nothing is optional in these plans, specifications or restrictions unless definitely stated as such.

The purpose of the restrictions under which Snipe hulls and sails are approved is to insure that, to as great a degree as possible, all hulls and sails have identical racing capability. It is impossible to list every single variation that might turn up in the future, and it is impossible to make any set of restrictions in which, at some future date, someone cannot find what appears to be a legal means of obtaining some racing advantage. Any boat or sail having features which are not consistent with this purpose will not be approved and cannot race even though there is no specific restriction preventing the item in question. Improvements and changes will be made only when these changes do not obsolete older boats from the standpoint of racing capability or when they can be accomplished by anyone at reasonable expense.

Approved Options Not Covered Elsewhere:

- Self-bailing cockpit: No restriction on method of construction.
- Hiking Straps: No restriction on number or location.
- Tiller Extension: No restriction on cross section or length.
- Boom Vang: No restriction on type. May be used at any time.
- Cleats for Jib Sheets or Mainsail Sheets: No restriction on number, type or location.
- Jib Fairleads: Any type or location permitted.

- Mainsheet Bridle: Any type or location permitted. May be adjusted while racing.
- Attachment of Jib Tack: The jib luff wire at the deck must be attached so it cannot be moved while racing. Tension on the cloth in the jib luff may be adjusted while racing. This restriction shall apply to all boats without regard to date of manufacturer.
- Mainsail Clew Outhaul: Any type permitted. May be adjusted while racing.
- Sliding Goosenecks: May be on track or in slot in mast. May be swiveling and may incorporate roller reefing gear. Must have some means to prevent downward movement beyond position giving maximum legal length of luff. The position of the gooseneck may be changed while racing.
- All metric measurements are taken to the nearest one-tenth of one millimeter. Questions must be resolved by using the customary system which is also shown, and which was used in designing the boat.
- Movement of the mast, fore and aft or lateral, may be restrained by blocks at the deck level. Fore and aft guys may be used, with the guys attached to the mast no higher than the top band of the lower set of bands. Mast shall not be moved at the maststep while racing.
- Floorboard are optional.
- FOR ALL BOATS: The maximum overall length of the whisker pole is 104" (2641.6 mm) and it may not extend in front of the bow of the boat or aft of the boom when not deployed. Pole launcher and retractor systems using shock cord are allowed.
- FOR ALL BOATS: Carbon or aramid fibers or micro-grooved film shall not be used in hull construction or major equipment. Exotic materials may be used in running rigging and fittings only if commercially manufactured and readily available on the open market at prices competitive with similar fittings and equipment of non-exotic material.
- No electronic devices other than timers shall be used on the boat.
- Boats must be measured by officially appointed or elected Fleet Measurers or by Class Measurers approved by SCIRA. No certificate shall be acceptable unless recommended and signed by such a Measurer. Boats must be weighed at the start of each season. Sails are subject to remeasurement and to cancellation of approval at any time. They must be measured at the start of each season and so marked. On any measured item (mast, boom, rudder, or centerboard), only one can be measured and these items can be changed only on irreparable damage or loss.

Hull

- Thickness of sides, transom, sides of centerboard trunk and bottom:
Fiberglass: 1/8" (3mm) min.
Fiberglass & Foam Sandwich or Fiberglass and Honeycomb Sandwich:
1/8" (3mm) Outerskin and 1/16" (1.5mm) Inner skin min.
Wood: Density of .0185 lbs per cubic inch (512 Kg per cu. meter) or greater - 1/2" (12.7mm) min. Density of less than .0185 lbs per cubic inch (512 Kg per cubic m) - 3/4" (19.1mm) min.
Plywood: 3/8" (9.5mm) min.
Plywood and fiberglass: 3/8" (9.5mm) minimum plywood, plus fiber glass.
Thickness of plywood deck: 1/4" (6.4mm) minimum. Exterior grade may be used.

- Keel width 4" (101.6mm) + or - 1/8" (3.2mm) on flat under surface from stern to station 2 and minimum 2" (50.8mm) wide at station 1.
- Stem must be a smooth curve and it must follow the table of stem offsets as shown on drawing.
- Maximum chine radius is 3/4" (19.1mm) at station 1, tapering to 1/8" (3.2mm) at station 2, and is 1/8" (3.2mm) from there aft.
- Maximum lack of flatness aft of station 1 in any cross section is 1/8" (3.2mm) per foot (304.8mm) of distance over which the lack of flatness is being checked.
- 15 - 18. Deliberately left blank.

Deck

- Forward deck. This must extend the full width of the boat to a point at least 72 1/2" (1841.5mm) aft of the stem. Maximum crown of deck 5" (127mm). The top of the sprayboards must be minimum 2" (50.8mm) vertically above deck for minimum 2' (609.6mm) of their respective lengths. Maximum projection of deck or sheer molding beyond sheer is 11/4" (31.8mm) in a horizontal plane, level with the sheer.
- After deck minimum 18" (457.2mm) in length.

Cockpit

- Maximum width of cockpit 40" (1016mm). If the deck alongside the cockpit curves down on a radius, the maximum width shall be checked at the intersection of the deck with a plane 2" (50.8mm) below the sheer. Cockpit corners may be square or rounded to any desired radius.

Centerboard

25. Verify dimensions with drawing. No other shape permitted. Slot in centerboard trunk maximum 21-1/2" (546.1mm) long and no more than 1/2" (12.7mm) in width if in fiberglass nor 9/16" (14.3mm) if in wood or plywood. The aft edge of centerboard trunk shall be perpendicular to base line. Forward edge of centerboard trunk shall either be perpendicular or slope forward 1/4" (6.4mm) maximum at the top of trunk.

Boards must be uniform thickness except within 1" (25.4mm) of edges which may be tapered off. Centerboard may be cut out for lightness. (See drawing.) The top of the front leg of a centerboard may be sloped back at an angle not greater than 45 degrees, starting at a point 12" (304.8mm) above the centerpunch mark 33-1/2" (850.9mm) from the bottom of the board. The handle of the centerboard shall be installed in such a manner that the aft edge of the centerboard is perpendicular to the base line when the centerboard is completely down.

26. **FOR ALL BOATS:** The centerboard must be restricted while racing, in such a manner that no point on the bottom edge extends less than 12 inches (304.8mm) below the keel. To permit checking the position of the centerboard while racing, a band 1" wide shall be painted on each side of the board, the top of the band being even with the surface of the deck at the centerline of the boat when the board is raised to this maximum height. A safety line must be used on the centerboard while racing. Any type of retaining system may be used, provided such system allows the crew to extend the board completely when capsized without swimming under the board.

27. The dimensions for centerboards as given on the drawing on the back of this sheet must be adhered to. There shall be no inserts or other means of changing the distribution of the weight. Centerboards shall be made of any hard aluminum alloy. 6061 T6 or its equivalent is recommended. The thickness of the centerboard shall be 3/8" (10mm). If seals are used on the centerboard trunk, they shall be used at the top of the trunk only. Any type of seals may be used.

Rudder

28. See that rudder is substantially made of wood, fiberglass or fiberglass and foam. See that tiller is strong and attached firmly to rudder head in such a manner that it cannot be slid fore and aft. There shall be a suitable means of preventing rudder from falling off with boat inverted.

29. The basic rudder thickness above and below the waterline shall be 3/4" (19.1mm) minimum and 1-1/2" (38.1mm) maximum.

31. The width of blade below waterline shall be 10-1/4" (260.4mm) maximum and 10" (254mm) minimum. This measurement is taken across rudder at approximately right angles to its leading edge.

32. Metal rudder blades are prohibited. Where pivoting rudders are desirable because of purely local conditions, they may be used for local point score races only. They may not be used in any regattas or championships.

Tillers must be direct connected and all above the aft deck. Rudder must at all times be mounted essentially parallel to the transom. Vertical adjustments or changes in angle are not permitted. Rudder must be attached to the transom and as close to the transom as conveniently possible with 1-1/2" (38.1mm) maximum clearance. The minimum weight of the rudder including pintles shall be 6 pounds (2.72 kg) on all boats.

Mast, Boom and Rigging

33. Only one mast may be used during a regatta unless irreparable damage has occurred. It shall be stepped on the keel, or no higher than 2" (50.8mm) above the top of flotation tank in bottom. The butt of the mast shall be positively retained in the step by means of a collar, cable or other suitable means.

34. The minimum allowable length from sheer molding shall be 20' 1" (6121.4mm).

35. The center line of the mast shall be located 60 (1524mm) to 64 inches (1625.6mm) aft of the stem. This measurement shall be taken to the mast step. The hole in the deck where the mast goes through the deck shall have a maximum size of 3" (76.2mm) athwartship x 10" (254mm) fore and aft. A 60" (1524mm) mark showing on either side of the mast step shall be molded in the hull.

36. Rotating masts are prohibited.

37. The mast must be minimum 1-1/4" (31.8mm) athwartships at the top band or at any point below. On all boats: Any taper in the mast above the stay intersection shall be essentially a uniform taper.

38. If mast is made of wood, it must be minimum 2" (50.8mm) athwartships and minimum 3" (76.2mm) fore and aft at deck. If mast is round (not streamlined), the dimension at deck shall be minimum 2-1/2" (63.5mm) in diameter.

39. Spreader length and rake limit shall not be adjustable while racing, on any boat.

41. Measure distance from sheer to the intersection of the jib stay with surface of the mast. See sketch on measurement drawing for method of determining the intersection. The shroud, jibstay, and jib halyard intersections with the surface of the mast shall be between 14' 8" (4470mm) and 15' 0" (4572mm) above the sheer. This shall apply to all boats built after January 1, 1992 and to replacement masts on older boats if so desired.

42. Halyards must be used, and they must lead down the mast toward the

boat, alongside or inside the mast. The length of the luff of the mainsail shall be limited while racing by the following means:

Bands 1" (25.4mm) wide shall be painted around the mast in color to contrast with the color of the mast, the bands being located as follows:

1. The lower edge of the top band to be not more than 20' 1/2" (6108.7mm) above the sheer.

2. An additional band, the upper edge of which shall be a maximum of 16' 9-1/4" (5111.8mm) below the lower edge of the corresponding top band.

3. Two additional bands, the lower edge of each band being 6" (152.4mm) below the lower edge of the previously specified bands, may be installed. These additional bands are optional.

In racing, the sail must be set so that the edge of the sail is limited at the top by the lower edge of one of the bands, and at the bottom by the top edge of a corresponding band. Tape which is not readily removable and which soon becomes as permanently attached as paint (such as one mil mylar) may be used for bands. Easily removable tape such as electricians or plastic decorative tape is not acceptable.

43. Length of boom shall be 8' 8" (2641.6mm) maximum, 8' 6" (2590.8mm) minimum, measured from the aft side of the mast (the aft side of the mast includes the sail slot and material enclosing the boltrope). A screw or other stopper shall limit the stretch of the mainsail foot so that the aftermost edge of the sail at the clew shall not be stretched beyond the following limit while racing: the aftermost edge of the sail at the clew shall not be farther aft than the forward edge of a band 1" (25.4mm) wide, and forward side of which is 8' 4-7/8" (2562.2mm) aft of the aft edge of sail slot in the mast.

44. The maximum depth of boom, no matter what type or material shall be 4" (101.6mm) at its widest point, minimum 3-1/2" (88.9mm) for a wood boom. Maximum width at any point 3" (76.2mm). Minimum thickness of plank boom 3/4" (19.1mm). If slotted boom is used, the maximum depth of 4" (101.6mm) includes the material forming the slot. Booms shall be essentially straight and shall not be tapered nor have lightening holes.

45. Aluminum extrusions may be used for masts and booms and masts may be tapered subject to Para. 37. Masts must be made of alloy 6061 T6 or equivalent. Booms may be made of alloy 6063 T6 or equivalent. Weight of such mast with winches, halyards, stays, gooseneck, spreaders and butt end must be at least 20 lbs (9.1 kg), and nothing may be added to the basic mast except necessary fittings or reinforcements. Center of gravity in the condition when weighed, with the stays and halyards extended full length and temporarily taped to the mast, shall be at least 60 inches (1524mm) above the upper band of the lower set of bands. Masts having an athwartship dimension of 2-1/8" (54mm) or less must use spreaders. Any section which may be used for a mast may be used for a boom. For booms only, a basic section 2-1/2" (63.5mm) deep and at least 7/8" (22.2mm) wide at its widest point may be used. The height of the boom at either end may be reduced for access to the boltrope.

46. Boom and mast may be slotted to take sail bolt rope provided dimensions are met.

47. Deliberately left blank.

48. All boats must have a jib stay and two side shrouds. The jib stay must be all metal 3/32" (2.4mm) minimum diameter, either wire or rod and must be fastened to a tang or other deck fitting. The length of the jib stay shall be such that it does not allow the mast to touch the back of the partner when the mast is restrained only by the jib stay and shrouds and the mast push/puller is off. **THIS APPLIES TO ALL BOATS.** No backstay may be used. Shroud anchorages or through-the-deck fairleads must be not more than 4" (101.6mm) in from the sheer, and between 70" (1778mm) and 78" (1981.2mm) aft of stem. Anchorages of jib stay and shrouds may be under deck, but location and length of jib stay and shrouds must be incapable of change during a race. The use of elastic light line between the shrouds and the mast is permitted.

50. All other rigging optional. So-called streamlined rigging not permitted. Running rigging optional. If, in the opinion of the Measurer, the rig shall be considered unsound, weak or unseaworthy, the Measurer must not recommend a Measurement Certificate. Changes must not be made after the Certificate is issued, unless the owner has Measurer recheck the rig.

Weight Limit

51. The boat complete must be weighed. This weight does not include paddle, life preservers, bailing equipment (unless permanently attached), sails or any other loose gear. It does include mast, boom, rigging, mainsheet, whisker pole or whisker pole launching system, centerboard, rudder and tiller. Boats that do not meet the weight limit must have weight permanently added before they can be given Measurement Certificates.

52. The weight of this boat as outlined above is 173.1 lbs (circle one)

Amount of ballast 3.95 lbs (circle one)

Ballast Location Must Be Marked on Diagram on Page Four

53. All boats must be weighed before issuing a measurement certificate and must be re-weighed at the start of each season.

54. The Measurer shall either witness the weighing of the boat or require the owner to furnish a weight certificate signed by at least two witnesses and the owner as well as the owner of the scales, that the minimum weight of the boat complete complies with this paragraph. The minimum weight shall be 381 lbs (172.8 Kg). The bare hull including deck, centerboard trunk, floorboards, flotation, hull fittings, and sailaway equipment shall weigh 276 lbs (125.2 Kg) minimum. In addition ballast up to 33 lbs (15 Kg) may be permanently added in any location, subject to the requirements for Moment of Inertia. All ballast must be installed where it may be seen and it shall be attached with peened over bolts or glass cloth. The bare hull including ballast as defined above shall be subjected to the moment of inertia test as contained in the Supplement to the Measurement Data Sheet for Moment of Inertia Test.

54.1 Effective January 1, 1996, measurement certificates given to owners shall include a hull diagram showing ballast weight and location and moment of inertia value.

55. Weight certificates from builders will not be accepted.
56. All boats shall comply with the following flotation requirement: When the boat has been capsized and has remained in any position long enough to take in as much water as possible in high wave conditions, it shall, upon being righted, float so that the lowest point around the cockpit edge where water might enter the boat is at least 6" (152.4 mm) above the water when the boat is supporting 300 lbs (136.1 kg). This may be accomplished by means of tanks, flotation bags, self-bailing cockpits, increased low density flotation material, or other suitable means. Holes with maximum total area 100 square inches (645.2 sq. cm) may be made in the transom to facilitate drainage. Where transom drains are used to comply with this rule they should have a minimum of 45 square inches (290.3 sq. cm) total. In boats meeting the requirements of this rule, the centerboard trunk may have a minimum height of 9" (228.6 mm) above the outside of the keel if the boat, after capsizing and being righted, floats high enough so that water will flow out of the trunk; otherwise, the trunk shall be 2" (50.8 mm) above the water level in the boat after capsizing and being righted.

Miscellaneous

58. Measurer must notify the owner of the following essential requirements: Boat must carry wearable life preservers for all occupants at all times, and race committees may require wearing them when racing when they consider it necessary. Suitable paddle or oar must be cared. A towline of 33' (10 meters) minimum length, and 1/4" (6mm) minimum diameter must be carried. SCIRA makes no prescription on anchors but some local authorities may require them. This applies to all boats.

59. There shall be no advertising matter whatever on the outside or inside of any boat or on its sails, except as allowed by the SCIRA Event Sponsorship Policy. Any boat infringing this ruling shall be subject to loss of measurement certificate. Measurers shall not issue a certificate to any such boat.

60. Name, complete mailing address and telephone or Fax number of Builder.

PERSSON MARINE

Strandvejen 352 C - DK-3060 Espergærde
Tel. +45 49 17 02 10 - Fax +45 49 17 06 20

61. Sliding seats, hiking boards, trapeze rigs, and other artificial methods of supporting the skipper's or crew's weight to balance the boat are prohibited. This does not prevent the use of hiking straps or any kind of line or cord attached to the boat within 8" (203.2 mm) of the top of the deck. It is permissible for the crew to hold on to the side stays.

Construction of Fiberglass Hulls

76. Only professional boat builders can make fiberglass Snipe hulls. Effective January 1, 1965, the construction of fiberglass hulls has been allowed under the same tolerances as approved by IYRU and now in effect for wood hulls. The loft lines do not show any sheer molding. Part or all of a sheer molding may be molded with the hull.

MATERIALS: Fiberglass cloth, woven roving or mat may be used, with either polyester or epoxy resins. Glass content must be at least 30% by weight.

FLOTATION: 6-1/2 cubic feet (.184 cu.m) of Styrofoam, Urethane foam, or equivalent, having a density of 2-1/2 kg per cubic foot (40 kg cu.m) maximum must be built into the hull. Balsa wood enclosed in resin-impregnated fiberglass cloth is considered equivalent. Supposedly airtight compartments are not considered adequate.

TOLERANCE: All fiberglass boats are to be measured to standard tolerances. The thickness of the hull must be uniform except where

reinforced locally such as at the keel, the chine, the stem, the mast step, and where the stay anchorages and rudder gudgeons are attached. Increased thickness due to incorporation of flotation material in either the sides or bottom of the hull is not a violation of this requirement. If desired, floorboards may be bonded directly to the bottom of the boat, omitting supports. A fiberglass and foam sandwich floor structure may be used. Wood and plywood are acceptable local reinforcements.

DECKS: the deck may be plywood as specified in the measurement data sheet, or it may be fiberglass. In general, a fiberglass deck will require some type of double surface and core construction to secure adequate stiffness. Each builder's method of construction must be approved by the Rules Committee.

Construction of Plywood Hulls

77. **BOTTOM AND SIDES:** The weight of the plywood used must be at least one pound, two and one-half ounces per square foot (5.65 kg. Per square meter). If 3/8 inch (9.5 mm) material is used throughout, fiberglass or other covering material may be used to bring the hull up to a minimum weight.

FLOTATION: Three cubic feet (.085 cu.m) of foam must be installed in the hull.

Moment of Inertia Test

78. All bare hulls, as defined in paragraph 54 must be subjected to the moment of inertia test. (For a full description of the method, see SUPPLEMENT TO THE MEASUREMENT DATA SHEET FOR MOMENT OF INERTIA TEST.)

The moment of inertia of the hull is calculated from the following formula:

$$I = \frac{CD^2T^2}{4\pi^2}$$

Where: I = Moment of Inertia
C = Spring constant, lb. per ft. (kg. per m.)
D = Distance to axis, ft. (m)
T = Time of one complete oscillation, seconds
 $\pi = 3.1416$

For our purpose, $D = 104" - 1" + 9/32" = 103.281" = 8.6067 \text{ ft} (2.6233 \text{ m})$
The spring constant will be furnished with springs from SCIRA.
We can now simplify the formula to:

$$\text{English: } I = \frac{8.6067 \text{ ft}^2 CT^2}{4 \times 3.1416^2} = 1.8763(CT^2) \text{ slugft.}^2$$

$$\text{Metric: } I = \frac{2.6233 \text{ m}^2 CT^2}{4 \times 3.1416^2} = .1743CT^2$$

The minimum moment of inertia of the hull as determined from the formula above shall be:

English - 200 (slug foot squared)
Metric - 27.6 (metric slug meters squared)

If the hull moment of inertia does not meet this minimum, weight shall be moved to or added to the ends to bring it up to the minimum.

The Moment of Inertia for this boat is:

218.8

Amount of weight and detailed description of location of weight added to conform to MOI requirements: (Location must be marked on diagram on page 4.)

1.95 KG 150 MM AFT OF C.B. TRUNK

1.30 KG 450 MM ——— 11 ———

0.30 KG 750 MM ——— 11 ———

Exception to Applicability of Prior Rules

The new centerboard shape and thickness must be used after January 1, 1976 on all boats in the World Championship, Western Hemisphere Championship and European Championship. Those existing boats which cannot use a 3/8" (10mm) thick board because of trunk slot width shall use a 5/16" (8mm) thick board of the new shape. The length of the trunk slot shall be 21-1/2 inches (546.1mm) maximum.

MEASURERS ARE CAUTIONED TO FILL OUT THIS DATA SHEET IN FULL AND AS ACCURATELY AS POSSIBLE:
 Those measurements found correct should be "circled" carefully on the drawing below, preferably with colored pencil.
 If certain measurements are *not* within the limits shown, cover same on the drawing with an "X" and use a reference letter
 or line across to your marginal note, giving the actual measurement.

Briefly note exceptions here
 (If additional explanatory
 sheet is attached, check. . .)

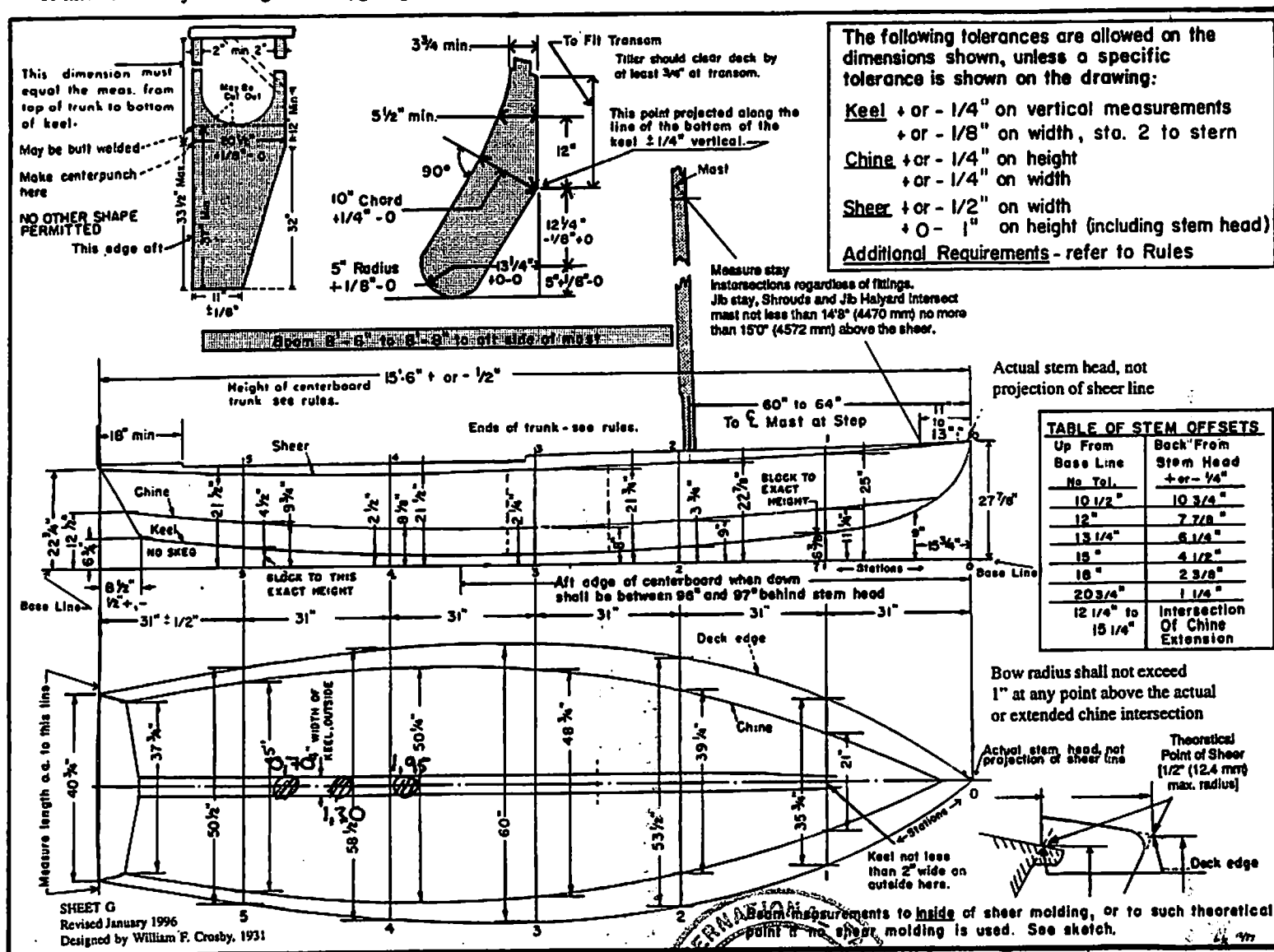

I hereby certify that I am the official measurer of the DANISH SAVING BOAT
 I certify and affirm that I have carefully measured this boat No. 302 to the best of my ability and that all the
 measurements written herein or checked by me were found to be exactly as indicated. I am ready and willing to swear
 to this before any accredited notary public.
 (Date) 2/4-2003 (Measurer's Signature) [Signature]

Note: The Fleet Measurer must under no circumstances give the Certificate of Measurement to the owner unless he is positive that the boat fully complies with these restrictions. If positive, the Measurer gives the Certificate to the owner and sends this Data Sheet to the Secretary.

SNIFE CLASS RACING ASSOCIATION

MEASUREMENT DATA SHEET FOR CERTIFIED BOATS

Revised February 2019

This page to be used for all boats. For measurements in Italic refer to the Class Rules

HULL NUMBER	30108	BUILDER	Person
MODEL	Persson	YEAR OF MANUFACTURE	2003
OWNER	Nuno Sá Cardoso	COUNTRY	PORTUGAL

BARE HULL	<input type="checkbox"/>	COMPLETE	<input checked="" type="checkbox"/>	INCOMPLETE	<input type="checkbox"/>
HULL MATERIAL: WOOD	<input type="checkbox"/>	FIBERGLASS	<input checked="" type="checkbox"/>	make note of	
DECK MATERIAL: WOOD	<input type="checkbox"/>	FIBERGLASS	<input checked="" type="checkbox"/>	incomplete items	
FROM CERTIFIED MOULD	<input checked="" type="checkbox"/>			filling the cells with NO	

HULL WEIGHT (min 125kg)	<input checked="" type="checkbox"/>	MAST LENGTH (Rules C.9.2, F.3.4)	<input checked="" type="checkbox"/>
TOTAL WEIGHT (min 172.8kg)	175.90 kg	Limiting marks & pin	<input checked="" type="checkbox"/>
CORRECTOR WEIGHTS (max 15kg)	5.0 kg	Corrector weigths (max 100gr)	0
MOI (27.6)	27.9	BOOM LENGTH (max 2642mm)	<input checked="" type="checkbox"/>
Spring set #	<input checked="" type="checkbox"/>	Limiting marks & pin	<input checked="" type="checkbox"/>
JIB FITTING	<input checked="" type="checkbox"/>	POLE LENGTH (max 2642mm)	<input checked="" type="checkbox"/>
(279-330mm hor. From Hull Datum Point)		RUDDER DIMENSIONS	<input checked="" type="checkbox"/>
max 45mm vert. above sheerline)		Weight (min. 2.72kg)	3.70 kg
SHROUDS (1778-1981mm from HDP)	<input checked="" type="checkbox"/>	Corrector weigths (Rule C.8.5)	0
MAST HOLE (min 1494-mm from HDP)	<input checked="" type="checkbox"/>	Parallel to transom (tolerance 2mm)	<input checked="" type="checkbox"/>
UPPER GUDGEON (Rule D.2.3)	N/A	DAGGERBOARD DIMENSIONS	<input checked="" type="checkbox"/>
LOWER GUDGEON (Rule D.2.3)	N/A	Band	<input checked="" type="checkbox"/>
GUDGEONS DIAMETER (Rule D.2.3)	N/A	Safety line (max 610mm long)	<input checked="" type="checkbox"/>
		Restraining system (hooks or tablet)	<input checked="" type="checkbox"/>

Insert the **actual** measurement in the cells marked as

Mark corrector weights position and amount below. Data to be copied on the Official Snipe Label

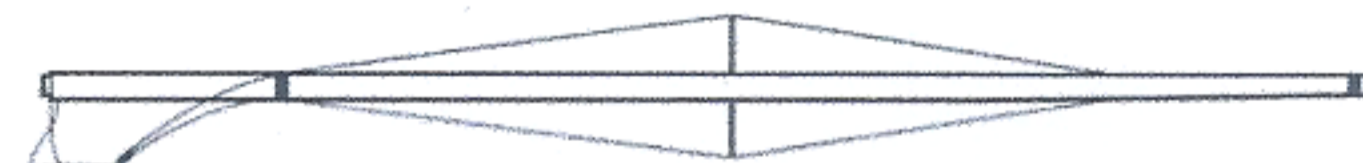
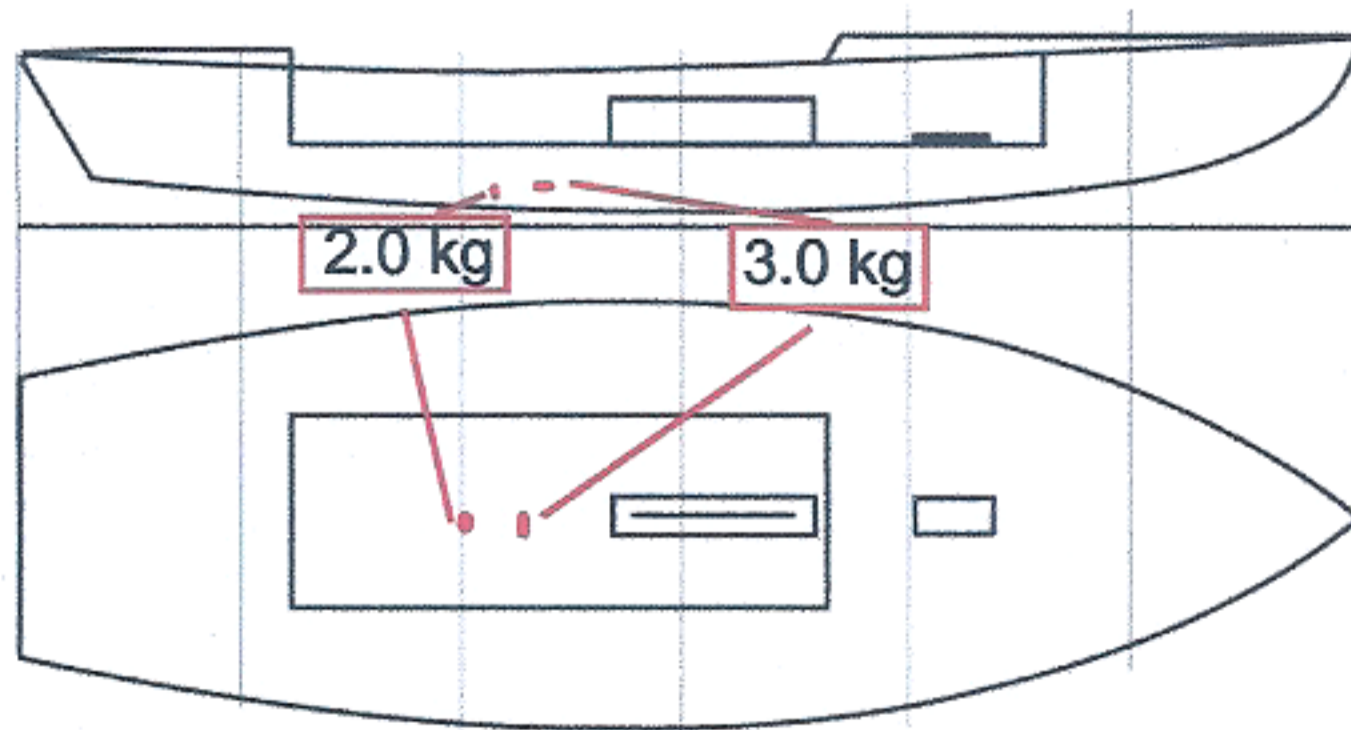

01 SCIRA MEASURER PORTUGAL

DATE MEASURED 7/5/2022

MEASURER'S STAMP

MEASURER'S NAME Domingos Borrvalho

NOTES: NATIONAL SECRETARY: Pedro Andrade