

SNIFE CLASS RACING ASSOCIATION

MEASUREMENT DATA SHEET FOR CERTIFIED BOATS

Revised February 2019

This page to be used for all boats. For measurements in Italic refer to the Class Rules

HULL NUMBER	30244	BUILDER	Skipper	
MODEL	Skipper	YEAR OF MANUFACTURE	2004	
OWNER	Gonçalo Dias Pinheiro	COUNTRY	PORTUGAL	

BARE HULL	<input type="checkbox"/>	COMPLETE	<input checked="" type="checkbox"/>	INCOMPLETE	<input type="checkbox"/>
HULL MATERIAL: WOOD	<input type="checkbox"/>	FIBERGLASS	<input checked="" type="checkbox"/>	make note of	
DECK MATERIAL: WOOD	<input type="checkbox"/>	FIBERGLASS	<input checked="" type="checkbox"/>	incomplete items	
FROM CERTIFIED MOULD	<input checked="" type="checkbox"/>		<input checked="" type="checkbox"/>	filling the cells with NO	

HULL WEIGHT (min 125kg)	<input checked="" type="checkbox"/>	MAST LENGTH (Rules C.9.2, F.3.4)	<input checked="" type="checkbox"/>
TOTAL WEIGHT (min 172.8kg)	172.80 KG	Limiting marks & pin	<input checked="" type="checkbox"/>
CORRECTOR WEIGHTS (max 15kg)	4+3 KG	Corrector weigths (max 100gr)	0
MOI	27.89	BOOM LENGTH (max 2642mm)	<input checked="" type="checkbox"/>
Spring set #	<input checked="" type="checkbox"/>	Limiting marks & pin	<input checked="" type="checkbox"/>
JIB FITTING (1° st hole of)	<input checked="" type="checkbox"/>	POLE LENGTH (max 2642mm)	<input checked="" type="checkbox"/>
(279-330mm hor. From Hull Datum Point)		RUDDER DIMENSIONS	<input checked="" type="checkbox"/>
max 45mm vert. above sheerline)		Weight (min. 2.72kg)	3.65 kg
SHROUDS (1778-1981mm from HDP)	<input checked="" type="checkbox"/>	Corrector weigths (Rule C.8.5)	0
MAST HOLE (min 1494-mm from HDP)	<input checked="" type="checkbox"/>	Parallel to transom (tolerance 2mm)	<input checked="" type="checkbox"/>
UPPER GUDGEON (Rule D.2.3)	N/A	DAGGERBOARD DIMENSIONS	<input checked="" type="checkbox"/>
LOWER GUDGEON (Rule D.2.3)	N/A	Band	<input checked="" type="checkbox"/>
GUDGEONS DIAMETER (Rule D.2.3)	N/A	Safety line (max 610mm long)	<input checked="" type="checkbox"/>
		Restraining system (hooks or tablet)	<input checked="" type="checkbox"/>

Insert the **actual** measurement in the cells marked as

Mark corrector weights position and amount below. Data to be copied on the Official Snipe Label

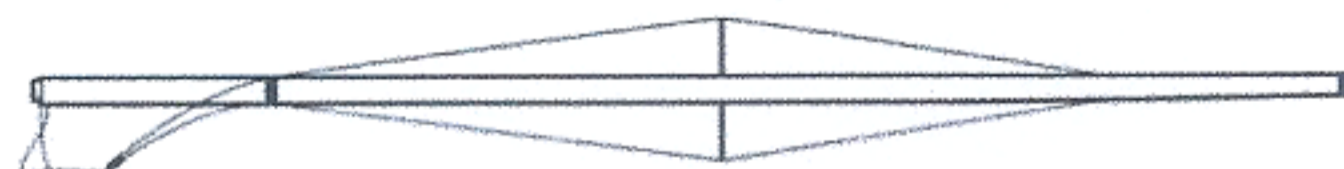
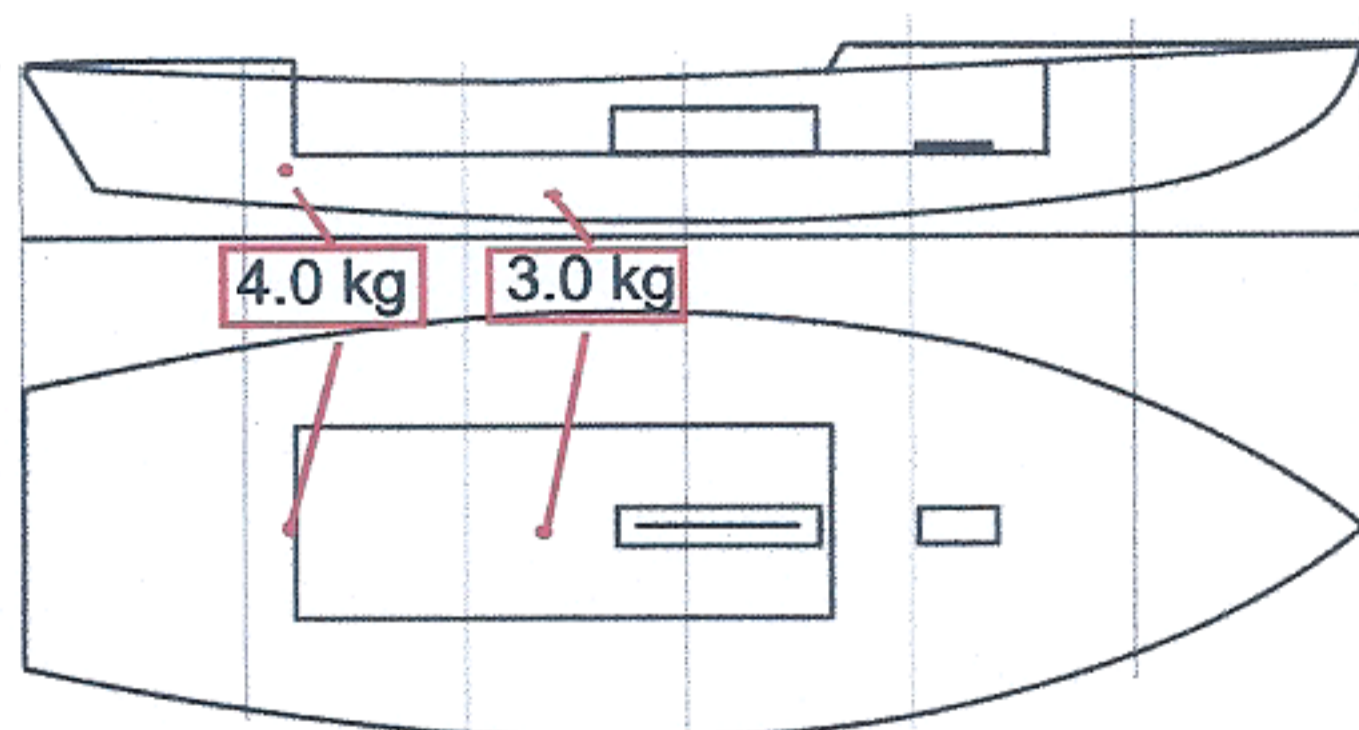

DATE MEASURED 07/05/2022

MEASURER'S STAMP

MEASURER'S NAME Domingos Borralho

NOTES: NATIONAL SECRETARY: Pedro Andrade

SCIRA
MEASURER
PORTUGAL

Pedro Andrade

Snipe Class International Racing Association