

# SNIPE CLASS RACING ASSOCIATION

## MEASUREMENT DATA SHEET Sheet I- revised January 2009 For boats built after January 1, 2009

HULL NUMBER.....30275..... BUILDER.....Skipper.....  
 MODEL.....Skipper..... YEAR.....2004.....  
 OWNER.....Luís Angeja / João Angeja..... COUNTRY.....Portugal.....

BARE HULL  COMPLETE  from certified mould  INCOMPLETE   
 HULL MATERIAL: WOOD  FIBERGLASS  *make note of*  
 DECK MATERIAL: WOOD  FIBERGLASS  *incomplete items*

HULL WEIGHT (MIN 125KG)	<input checked="" type="checkbox"/>	MAST LENGTH (6499MM)	<input checked="" type="checkbox"/>
TOTAL WEIGHT (172.8KG)	<input checked="" type="checkbox"/>	Limiting bands & pin	<input checked="" type="checkbox"/>
BALLAST (MAX 15KG mark below)	<input checked="" type="checkbox"/>	BOOM LENGTH (2642MM from aft edge of mast)	<input checked="" type="checkbox"/>
MOI	<input checked="" type="checkbox"/>	Limiting bands	<input checked="" type="checkbox"/>
JIB FITTING (279-330 dist. from pt 0)	<input checked="" type="checkbox"/> 1° OF	POLE LENGTH (2642MM)	<input checked="" type="checkbox"/>
SHROUDS (1778-1981mm dist. from pt. 0)	<input checked="" type="checkbox"/>	RUDDER DIMENSIONS	<input checked="" type="checkbox"/>
UPPER GUDGEON (410+/-3MM)	<input type="checkbox"/> N/A	RUDDER WEIGHT (2.72kg)	<input checked="" type="checkbox"/>
LOWER GUDGEON (155 +/-3MM)	<input type="checkbox"/> N/A	Fits the Transom (Y/N)	<input checked="" type="checkbox"/>
MAST HOLE (1494mm dist. from pt. 0)	<input checked="" type="checkbox"/>	CENTERBOARD DIMENSIONS	<input checked="" type="checkbox"/>
TRUNK HEIGHT (310 -0+3MM)	<input checked="" type="checkbox"/>	Band	<input checked="" type="checkbox"/>
		Restraining System & stoppers	<input checked="" type="checkbox"/>

Mark ballast here

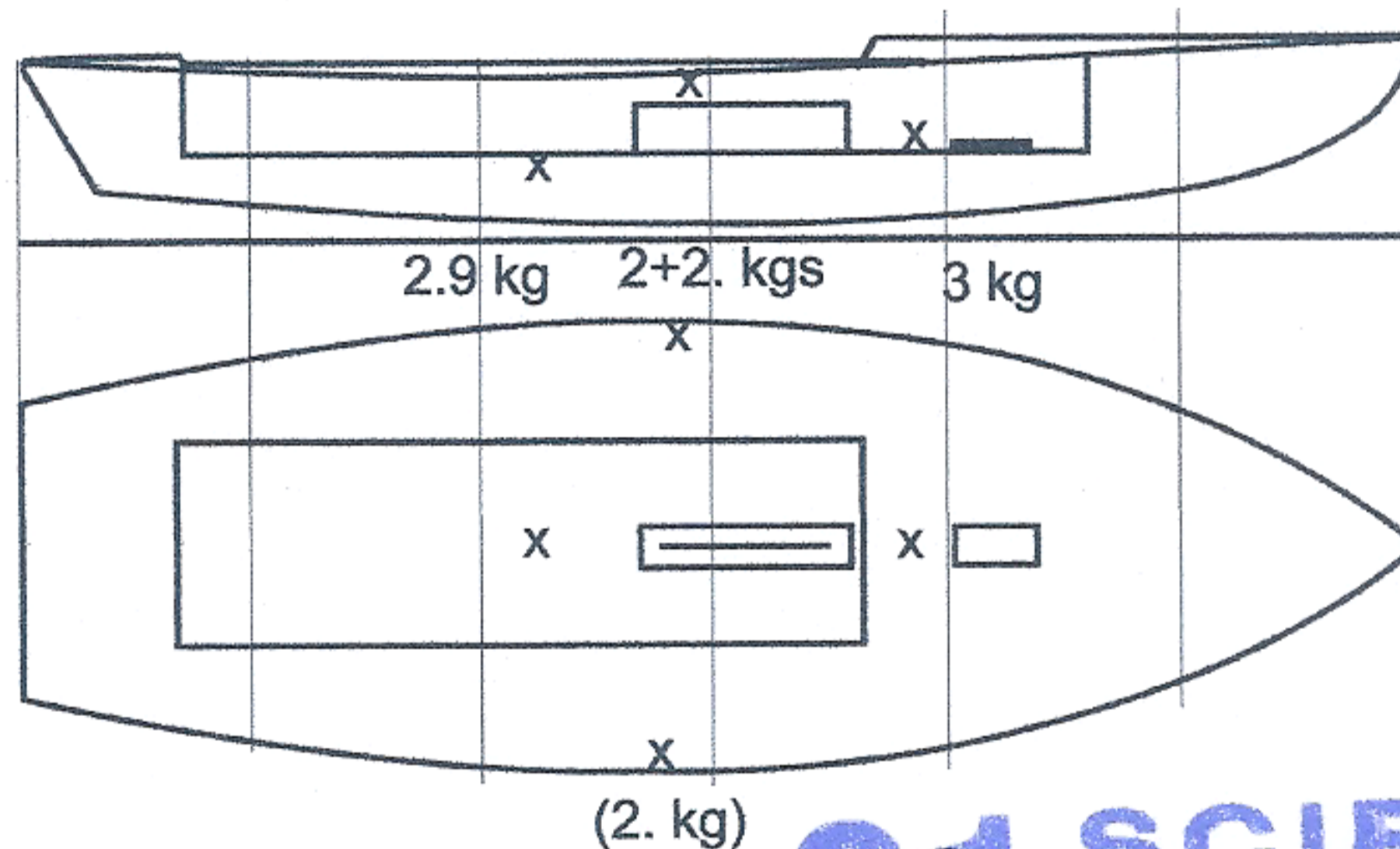

DATE MEASURED.....27/03/2022.....

MEASURER'S SIGNATURE ..Domingos Borralho.....

MEASURER'S STAMP.....

NOTES: NATIONAL SECRETARY: ..Pedro Andrade.....

**SCIRA**  
**MEASURER**  
**PORTUGAL**

**Both pages must be completed and sent to the SCIRA office upon completion of measurement except if hull is from a certified mould.**

# SCIRA Measurement Check Sheet

To be used with the 80/20 true baseline measurement frame

Owner: Luís Angeja / João Angeja Date: 27/03/2022

Hull # 30275 Builder: Skipper Material: F. G.

## Chines Height

Station	Starboard	Port	Total	Allowable Range	Width	Allowable Range
1				838-864		527-540
2				724-749		991-1003
3				673-699		1232-1245
4				680-705		1270-1283
5				762-787		1137-1149
Transom				902-927		952-965

## Sheer

Station	Starboard	Port	Total	Allowable Range	Width	Allowable Range
1				1499-1549		895-921
2				1391-1441		346-1372
3				1333-1384		1511-1537
4				1321-1372		1473-1499
5				1321-1372		1270-1295
Transom				1384-1435		1022-1048

## Keel

	Height	Width
400mm		
1		
2		
3		
4		
5		
Transom		

## Rudder

Weight	3.45 kg
2.72kg	
Shape	✓
Thickness	✓
Lock	✓
Keel Ext.	✓

## Daggerboard

Bottom	✓
Shape	✓
Thickness	✓
Stripe	✓
Punch mark	✓
Tapers	✓

Horizontal Transom Offset 203-229 LOA 4711-4737

Weight 175.200 kg Ballast (lead) 9.90 kg MOI >27.6 28.51

## Mast

Band loc	✓
Length <6499mm	✓
Limiting pin	✓
Sheer mark	✓
Weight/bal 9.1kg	✓

## Boom

Band loc 2559mm	✓
Limiting pin	✓
Max Length <2642mm	✓
Pole length <2642mm	✓

## Bow

Stem height 683-708	
Bow radius	

## Topside Measurements

Aft end of Trunk 2438-2464 from stem	✓	Length of daggerboard slot	✓
Top of trunk parallel to baseline	✓	Width of daggerboard slot	✓
Aft edge of trunk perpendicular to baseline	✓	Stem to mast partner >1494	✓
Keel to top of trunk 310-313	✓	Length of foredeck >1842	✓
Shroud fitting to stem 1778-1981	✓	Length of aft deck >457	✓
Mast step to sheer (vertical) 390-400	✓	Headstay to stem 279-330	✓ 1° OF

Measurer Domingos Borralho

SCIRA MEASURER PORTUGAL

# SNIPE CLASS RACING ASSOCIATION

## MEASUREMENT DATA SHEET Sheet I- revised January 2009 For boats built after January 1, 2009

HULL NUMBER POR 30275 BUILDER Skipper  
 MODEL Skipper YEAR 2004  
 OWNER Bernardo Dias Pinheiro COUNTRY Portugal

BARE HULL  COMPLETE  from certified mould  INCOMPLETE   
 HULL MATERIAL: WOOD  FIBERGLASS  *make note of*  
 DECK MATERIAL: WOOD  FIBERGLASS  *incomplete items*

HULL WEIGHT (MIN 125KG)	<input checked="" type="checkbox"/>	MAST LENGTH (6499MM)	<input checked="" type="checkbox"/>
TOTAL WEIGHT (172.8KG)	<input checked="" type="checkbox"/>	Limiting bands & pin	<input checked="" type="checkbox"/>
BALLAST (MAX 15KG mark below)	<input checked="" type="checkbox"/>	BOOM LENGTH (2642MM from aft edge of mast)	<input checked="" type="checkbox"/>
MOI	<input checked="" type="checkbox"/>	Limiting bands	<input checked="" type="checkbox"/>
JIB FITTING (279-330 dist. from pt 0)	<input checked="" type="checkbox"/>	POLE LENGTH (2642MM)	<input checked="" type="checkbox"/>
SHROUDS (1778-1981mm dist. from pt. 0)	<input checked="" type="checkbox"/>	RUDDER DIMENSIONS	<input checked="" type="checkbox"/>
UPPER GUDGEON (410+/-3MM)	<input type="checkbox"/>	RUDDER WEIGHT (2.72kg)	<input checked="" type="checkbox"/>
LOWER GUDGEON (155 +/-3MM)	<input type="checkbox"/>	Fits the Transom (Y/N)	<input checked="" type="checkbox"/>
MAST HOLE (1494mm dist. from pt. 0)	<input checked="" type="checkbox"/>	CENTERBOARD DIMENSIONS	<input checked="" type="checkbox"/>
TRUNK HEIGHT (310 -0+3MM)	<input checked="" type="checkbox"/>	Band	<input checked="" type="checkbox"/>
		Restraining System & stoppers	<input checked="" type="checkbox"/>

Mark ballast here

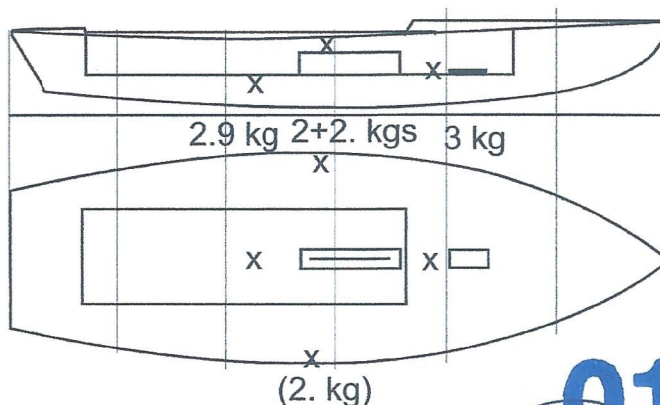

DATE MEASURED 30/09/2014

MEASURER'S SIGNATURE Domingos Borralho

MEASURER'S STAMP Pedro Andrade

**01 SCIRA  
MEASURER  
PORTUGAL**

NOTES: Certificado emitido e entregue em Março de 2015

**Both pages must be completed and sent to the SCIRA office upon completion of measurement except if hull is from a certified mould.**

# SCIRA Measurement Check Sheet

To be used with the 80/20 true baseline measurement frame

Owner: Bernardo Dias Pinheiro Date: 30/09/2014

Hull # 30275 Builder: Skipper Material: F. G.

## Chines Height

Station	Starboard	Port	Total	Allowable Range	Width	Allowable Range
1				838-864		527-540
2				724-749		991-1003
3				673-699		1232-1245
4				680-705		1270-1283
5				762-787		1137-1149
Transom				902-927		952-965

## Sheer

Station	Starboard	Port	Total	Allowable Range	Width	Allowable Range
1				1499-1549		895-921
2				1391-1441		346-1372
3				1333-1384		1511-1537
4				1321-1372		1473-1499
5				1321-1372		1270-1295
Transom				1384-1435		1022-1048

## Keel

	Height	Width
400mm		
1		
2		
3		
4		
5		
Transom		

## Rudder

Weight	3.45 kg
2.72kg	
Shape	X
Thickness	X
Lock	X
Keel Ext.	X

## Daggerboard

Bottom	X
Shape	X
Thickness	X
Stripe	X
Punch mark	X
Tapers	X

Horizontal Transom Offset 203-229 LOA 4711-4737

Weight 173.450 kg Ballast (lead) 9.90 kg MOI >27.6 28.51  
Mast Boom Bow

Band loc	X
Length <6499mm	X
Limiting pin	X
Sheer mark	X
Weight/bal 9.1kg	X

Band loc 2559mm	X
Limiting pin	
Max Length <2642mm	X
Pole length <2642mm	X

Stem height 683-708	
Bow radius	

## Topside Measurements

Aft end of Trunk 2438-2464 from stem	X	Length of daggerboard slot	X
Top of trunk parallel to baseline	X	Width of daggerboard slot	X
Aft edge of trunk perpendicular to baseline	X	Stem to mast partner >1494	X
Keel to top of trunk 310-313	X	Length of foredeck >1842	X
Shroud fitting to stem 1778-1981	X	Length of aft deck >457	X
Mast step to sheer (vertical) 390-400	X	Headstay to stem 279-310	X

Measurer Domingos Borralho

01 SCIRA MEASURE PORTUGAL