

SNIFE CLASS INTERNATIONAL RACING ASSOCIATION

MEASUREMENT DATA SHEET

Sheet H - Revised January 2001
For all boats built after January 1, 2001
EXCEPT AS NOTED

Use Standard Marking Procedure on this form:

- When NOT within the tolerance limits allowed, mark an "X" in the margin and state actual measurements.
- Otherwise, do not write in the measurements of this boat except where specifically called for.
- Draw a circle around the number of each paragraph when you have verified or carried out all its details.
- When your examination is completed, every paragraph number will be "circled" (indicating conformity); or will bear an "X" in the margin (indicating something needs to be rebuilt or submitted to the International Rules Committee for decision).

PLEASE PRINT

(a) Measurers must fill in every blank space provided on the Measurement Data Sheet. Each dimension shown must be verified by the measurer and if the dimension is not either the maximum or minimum or between the two, the measurer may recommend certificate good for local races only on home built boats, if discrepancy is MINOR and clearly shown. No discrepancies permitted on professionally built boats.

(b) Each boat must have been assigned a racing number by the Association. This number must be carved, burned, or molded into the centerboard trunk in an unobscured position. Minimum height of these numbers must be 13mm (1/2"). Unless this is done, a boat cannot receive a Certificate of Measurement.

(c) In order to be eligible to race, every boat must have an official decal for the current year, permanently attached to the starboard side just forward of the transom. Decals will be issued by the appropriate National Secretary for each year that dues are paid.

Official Racing Number of boat on trunk 30294

Boat's Name _____

Full name(s) and address(es) of owner(s) Hector Concha

Name and charter number of the fleet in which this boat is expected to compete. Niteroi - 477

Name, complete mailing address and telephone or fax number of builder. Rui Diemer - Petropolis, RJ
Brazil - (024) 2239.4968

GENERAL RESTRICTIONS

- The purpose of the restrictions under which Snipe hulls and sails are approved is to ensure that, to as great degree as possible, all hulls and sails have identical racing capability. It is impossible to list every single variation that might turn up in the future, and it is impossible to make any set of restrictions, which at some future date, someone cannot find what appears to be a legal means of obtaining some racing advantage. Any boat or sail having features which are not consistent with this purpose will not be approved and cannot race even though there is no specific restriction preventing the item in question. Improvements and changes will be made only when these changes do not obsolete older boats and sails from the standpoint of racing capability or when they can be accomplished by anyone at reasonable expense.
- Boats must be measured by officially appointed or elected Fleet Measurers or by Class Measurers approved by SCIRA. No certificate shall be acceptable unless recommended and signed by such a Measurer. (See also Certified Builder Rule on page 54)
- Boats, to be eligible to race in this Class, must be built to conform in every way to these measurement rules. A boat that does not meet all these requirements shall be ineligible to receive a Certificate of Measurement, but it retains its identifying number. Such boats cannot take part in any open or closed regattas whatsoever. The measurer must notify the Executive Director of any boats that cannot pass these requirements, giving the boat number, and the name and address of both the builder and owner.
- Nothing is optional in these plans, specifications or restrictions unless definitely stated as such.

Hull

- Thickness of sides, transom, sides of centerboard trunk and bottom:
Fiberglass: 3mm (1/8") minimum
Fiberglass and foam sandwich or fiberglass and honeycomb sandwich: 3mm (1/8") outer skin and 1.5mm (1/16") inner skin minimum.
Wood: density of 512 kg per cubic meter (.0185 lbs. per cubic inch) or greater, 13mm (1/2") minimum. Density of less than 512 kg per cubic meter (.0185 lbs. per cubic inch), 19mm (3/4") minimum.
Plywood: 10mm (3/8") minimum.
Plywood and fiberglass: 10mm (3/8") minimum plus fiberglass.
- Keel width 102mm (4") plus or minus 3mm (1/8") on flat under surface from stern to station 2 and minimum 51mm (2") wide at station 1.
- Stem must be a smooth curve and it must follow the table of stem offsets shown on drawing.
- Maximum chine radius is 19mm (3/4") at station 1, tapering to 3mm (1/8") at station 2, and is 3mm (1/8") from there aft.
- Maximum lack of flatness aft of station 1 in any cross section is 3mm (1/8") per each 305mm (foot) of distance over which the lack of flatness is being checked (i.e. distance 305 mm = 3mm, distance 456 mm = 4.5 mm, distance 610 mm = 6 mm of lack of flatness).

Deck

- Thickness: Plywood: 6mm (1/4") minimum. Exterior grade maybe used.
Fiberglass: 1.5mm (1/16"), Fiberglass and foam or honeycomb: 1.5mm (1/16") outer skin minimum.
- Forward deck must extend the full width of the boat to a point at least 184mm (7 1/2") aft of the stem.
- Afterdeck minimum 457 mm (18") in length.
- Maximum crown of deck 127 mm (5").
- The top of the spray boards must be minimum 51 mm (2") vertically above deck for minimum of 610 mm (2") on either side of the centerline.
- Maximum projection of deck or sheer molding beyond sheer is 32 mm (1 1/4") in a horizontal plane, level with the sheer.
- The hole in the deck where the mast goes through the deck (partners) shall have a maximum size of 76mm (3") athwartship by 254mm (10") fore and aft. The front side of the hole shall not be more than 1499mm (58 7/8") aft of the stem*.

Cockpit

- Maximum width: 1016 mm (40"). If the deck alongside the cockpit curves down on a radius, the maximum width shall be checked at the intersection of the deck with a plane 51 mm (2") below the sheer. Cockpit corners may be square or rounded to any desired radius.

Construction of Fiberglass Boats

- Only professional boat builders certified by SCIRA can make fiberglass Snipe hulls (See Certified Builder Rule, page 54) Effective January 1, 1965, the construction of fiberglass hulls has been allowed under the same tolerances as approved by ISAF and now in effect for wood hulls. The loft lines do not show any sheer molding. Part or all of a sheer molding may be molded with hull. Each builder's method of construction of fiberglass boats must be approved by the Rules Committee. The thickness of the hull must be uniform except where reinforced locally such as at keel, the chine, the stem, the mast step, and where the stay anchorages and rudder gudgeons are attached. Increased thickness due to incorporation of flotation material in either the sides or bottom of the hull is not a violation of this requirement. If desired, the floorboards may be bonded directly to the bottom on the boat, omitting supports. A fiberglass and foam sandwich floor structure may be used. Wood and plywood are acceptable local reinforcements.
- All professionally built boats must be measured before leaving the factory by a measurer satisfactory to the builder and the national secretary. Boats not so measured are prohibited from competition at regattas above the local level until measurement is complete. Complete measurement includes a Moment of Inertia test.
Materials: fiberglass cloth, woven roving or mat may be used, with either polyester or epoxy resins. Glass content must be at least 30% by weight.
Deck: The deck may be plywood or it may be fiberglass. In general, a fiberglass deck will require some type of double surface and core construction for adequate stiffness.
Flotation: .184 cu.m. (6 1/2" cubic feet) of Styrofoam, Urethane foam, or equivalent, having a density of 40 kg cu.m. (2 1/2 kg per cubic foot) maximum must be built into the hull. Balsa wood or foam enclosed in resin-impregnated fiberglass cloth is considered equivalent. Supposedly airtight compartments are not considered adequate.

Construction of Plywood Hulls

14. Bottom and Sides: The weight of the plywood used must be at least 5.65 kg per square meter (18 1/2 ounces per square foot). If 10mm (3/8") material is used throughout, fiberglass or other covering material may be used to bring the hull up to a minimum weight.

Flotation: .085 cu.m. (3 cubic feet) of foam must be installed in the hull. 15. All boats shall comply with the following flotation requirement: when the boat has been capsized and has remained in any position long enough to take in as much water as possible in high wave conditions, it shall, upon being righted, float so that the lowest point around the cockpit edge where water might enter the boat is at least 152mm (6") above the water when the boat is supporting 136 kgs (300 lbs). This may be accomplished by means of tank, flotation bags, self-bailing cockpits, increased low density flotation material, or other suitable means. Holes with maximum 645.2 sq.cm. (100 square inches) may be made in the transom to facilitate drainage. Where transom drains are used to comply with this rule they should have a minimum of 290.3 sq.cm. (45 square inches) total. For boats built before Jan. 1, 2001 meeting the requirements of this rule, the centerboard trunk may have a minimum height of 9" (229mm) above the outside of the keel if the boat, after capsizing and being righted, floats high enough so that water will flow out of the trunk; otherwise, the trunk shall be 51mm (2") above the water level in the boat after capsizing and being righted.

Moment of Inertia Test

16. All bare hulls, as defined in paragraph 38, must be subject to the moment of inertia test (for a full description of method, see Supplement to Measurement Data Sheet for Moment of Inertia Test). The moment of inertia of the hull is calculated from the following formula:

Where: I = Moment of Inertia
C = Spring constant, lb. per ft. (kg. per m.)
D = Distance to axis, ft. (m.)
T = Time of one complete oscillation, seconds
= 3.1416

$$I = \frac{CD^2T^2}{4\pi^2}$$

For our purpose, $D = 104" - 1" + 9/32" = 103.281" = 8.6067 \text{ ft} (2.6233 \text{ m})$.
The spring constant will be furnished with springs from SCIRA.

We can now simplify the formula to:

$$\text{English: } I = \frac{8.6067 \text{ ft}^2 CT^2}{4 \times 3.1416^2} = 1.8763(CT^2) \text{ slugft.}^2$$

$$\text{Metric: } I = \frac{2.6233 \text{ m}^2 CT^2}{4 \times 3.1416^2} = .1743CT^2$$

The minimum moment of inertia of the hull as determined from above formula shall be:

Metric: 27.6 (metric slug meters squared)
English: 200 (slug foot squared)

If the hull moment of inertia does not meet the minimum, weight shall be moved to or added to the ends to bring it up to the minimum.

The Moment of Inertia for this boat is:

27.71 slug/m²

Amount of weight and detailed description of location of weight added to conform to MOI requirements (location must be marked on diagram on page 3 & 4.)

Centerboard

17. Board: Verify dimensions with drawing, no other shape permitted. Maximum radius of bottom corners 13mm (1/2")*. Centerboard shall be made of any hard aluminum alloy, 6061T6 or its equivalent is recommended. The thickness of centerboard shall be 10mm (3/8"). There shall be no inserts or other means of changing the distribution of the weight. Boards must be uniform thickness except within 25mm (1") of edges, which may be tapered off. Centerboards may be cut out for lightness (see drawing). The handle of the centerboard shall be installed in such a manner that the aft edge of the centerboard is perpendicular to the base line when the centerboard is completely down, and the centerboard shall not extend more than 851mm (33 1/2") below the keel. The 851mm (33 1/2") point shall be marked at aft edge on starboard side by a center punch.

17.1 Effective Jan. 1, 2001, centerboards complying with the measurement restrictions set out in Rule 17.1 (above) made of sheet molding compound (SMC) manufactured by Inapal Plasticos of Portugal may be used in any Snipe regatta up to, but not including, national championships and major international championships. In addition however, the national sec-

retary of any SCIRA country may approve the use of the SMC centerboard in the national championship of that country. Boats sailing with the SMC centerboard must add weight where it may be easily seen if necessary to comply with minimum weight restrictions of the Class. Such weight shall be permanently attached with peened over bolts, glass cloth, or permanent mastic. Only one centerboard may be measured and used at a regatta.

17.2 Trunk: Slot in centerboard trunk maximum 546mm (21 1/2") long and no more than 13mm (1/2") in width if in fiberglass or 14mm (9/16") if in wood or plywood. The aft edge of the centerboard trunk shall be perpendicular to base line. Forward edge of centerboard trunk shall either be perpendicular or slope forward 6mm (1/4") maximum at the top of trunk. If seals are used on the centerboard trunk, they shall be used at the top of the trunk only. Any type of seals may be used.

For all boats built after Jan. 1, 2001: the aft end of the centerboard trunk must be 310mm, -0 + 3mm (12 1/4", -0" + 1/8") from the outside of the hull to the top of the trunk. The top of centerboard trunk shall be parallel to baseline*.

18. The centerboard must be restricted while racing in such a manner that no point of the bottom edge extends less than 305mm (12") below the keel. To permit checking the position of the centerboard while racing a band 25mm (1") wide shall be painted on each side of the board. The top of the band being even with the surface of the deck at the centerline of the boat while the board is raised on this maximum height. A safety line must be used on centerboard while racing. The safety line shall not be adjustable and shall be fastened to the boat and to the centerboard by a shackle or snap of suitable dimension.* Any type of retaining system may be used, provided such system allows the crew to extend the board completely when capsized without swimming under the boat. Only one centerboard may be used during a regatta unless irreparable damage has occurred.

Exception to Applicability of Prior Rules (#17 & #18)

The new centerboard shape and thickness must be used after January 1, 1976 on all boats in the World Championships, Western Hemisphere Championships and European Championships. Those existing boats which cannot use a 10mm (3/8") thick board because of trunk slot width shall use a 8mm (5/16") thick board of the new shape. The length of the trunk slot shall be 546mm (21 1/2") maximum.

Rudder

19. The rudder shall be made of wood, wood & fiberglass, fiberglass or fiberglass & foam. Metal rudder blades are prohibited. Only one rudder may be used during a regatta unless irreparable damage has occurred.

20. The rudder thickness above and below the water line shall be 19mm (3/4") minimum and 38mm (1 1/2") maximum.

21. The width of the blade below the water line shall be 260mm (10 1/4") maximum and 254mm (10") minimum. This measurement is taken across the rudder approximately at right angles to its leading edge.

22. The minimum weight of the rudder including pintles shall be 2.72 kgs (6 pounds). Weight of no more than 450g. (1 lb.) may be permanently attached to a rudder to reach the minimum weight.

23. Where pivoting rudders are desirable because of purely local conditions, they may be used for local races only. They may not be used in any regattas or championships.

24. The tiller shall be strong and attached firmly to the rudder head in such a manner it cannot be slid fore and aft and does not extend far enough aft to artificially lengthen the boat. Tiller must be directly connected and completely above the aft deck.

25. The rudder must at all times be mounted parallel to the transom. It must be attached to the transom and as close to the transom as conveniently possible with 38mm (1 1/2") maximum clearance. Vertical adjustments or changes in angle are not permitted. There shall be a suitable means of preventing the rudder from falling off with the boat inverted.

26. The gudgeons & pintles shall be 8mm (5/16") diameter.*

26.1. The lower gudgeon shall be mounted on the transom 155mm (6 1/8") above the intersection of the transom and the keel. The upper gudgeon shall be 410mm (16 1/8") above the intersection of the transom and keel.

Mast - Boom - Rigging

27. Only one mast may be used during a regatta unless irreparable damage has occurred. The mast must be minimum 32mm (1 1/4") athwartships at the top band or at any point below. The mast may be tapered above the stay intersection. Any taper in the mast above the stay intersection shall be essentially a uniform taper. Aluminum extrusions may be used and must be made of alloy 6061T6 or equivalent. Masts having an athwartship dimension of 54mm (2 1/8") or less must use spreaders. Spreader length and rake limit shall not be adjustable while racing. Rotating masts are prohibited.

27.1 When stepped, the centerline of the mast shall be located between 1524mm (60") and 1626mm (64") aft of the stem. (For measurement purposes the front side of the mast should be between 1494mm (58 7/8") and 1600mm (63") from the stem with the mast in vertical position)*

27.2 For all boats built after Jan. 1, 2001: The floor of the mast step fitting must be no more than 400mm (15 3/4") and no less than 390mm (15 3/8") below the sheer line. For older boats: The mast shall be stepped on the keel, or no higher than 51mm (2") above the flotation tank in the bottom.

28. Halyards must be used, and they must lead down the mast toward the boat, alongside, or inside the mast.

28.1 The shroud, jib stay, and jib halyard intersections with the surface of the mast shall be between 4470mm (14'8") and 4572mm (15'0") above the sheer. See drawing for method of determining the intersection. This limitation shall apply to all masts built after Jan. 1, 1992 and before Jan. 1, 2001.

For all boats built after Jan. 1, 2001: The shroud, jib stay, and jib halyard intersections with the surface of the mast shall be between 4860mm (15'11 3/8") and 4962mm (16'3 3/8") above the butt of the mast.

29. Two bands of 25mm (1") width shall be painted around the mast in a color to contrast with color of the mast. Tape which is not readily removable and which soon becomes as permanently attached as paint (such as one mil Mylar) may be used. Easily removable tape such as electricians or plastic decorative tape is not acceptable.

The bands shall be located as follows:

The lower edge of the top band to be not more than 6109mm (20' 1/2") above the sheer (Need not be measured on boats built after Jan. 1, 2001).

For all boats built after Jan. 1, 2001: The lower edge of the top band to be not more than 6499mm (21' 3 7/8") above the butt of the mast.

The upper edge of lower band shall be at maximum 5112mm (16' 9 1/4") below the lower edge of top band.

While racing the main sail must be set so that its edges are within the inside edges of the bands.

30. The mast with halyards, stays, gooseneck, stay adjusters, spreaders and butt fitting must weigh 9.1 kg (20 lbs) minimum and nothing may be added to the basic mast except necessary fittings or reinforcements. The center of gravity in the conditions when weighed with the stays and halyards full length and temporarily taped to the mast, shall be at least 1524mm (60") above the lower band. If the mast complies with this rule it will remain legal if a blade or other reinforcement is added*.

31. All boats must have a jib stay and two side shrouds. No backstay may be used. The jib stay must be all metal 2.5mm (3/32") minimum diameter, either wire or rod and must be fastened to a tang or other deck fitting. The length of the jib stay shall be such that it does not allow the mast to touch the back of the partner when the mast is restrained only by the jib stay with shrouds and the mast push/puller off. The length of jib stay and shrouds must be incapable of being changed during a race.

31.1 Anchorages of shrouds may be under deck. Shroud anchorages or through-the-deck fairleads must be not more than 102mm (4") inside the sheer line and between 1778mm (70") and 1981mm (78") aft of the stem.

31.2 The butt of the mast shall be positively retained in the step by means of a collar, cable or other suitable means. Movement of the mast, fore and aft, or lateral, may be restrained by blocks at deck level. Fore and aft guys may be used, with the guys attached to the mast no higher than the lower band. Mast shall not be moved at step while racing.

31.3 The use of light elastic line (shock cord) to remove slack in the jib stay and between the shrouds and the mast is permitted.

31.4 All other rigging optional. Running rigging optional. So-called streamlined rigging not permitted.

32. The boom length shall be 2642mm (8' 8") maximum, measured from the aft side of the mast.

33. The maximum depth of boom, including slot, shall be 102mm (4") and minimum 89mm (3 1/2") for a wood boom. Maximum width 76mm (3"). Minimum thickness of plank boom 19mm (3/4"). A section of 63mm (2 1/2") deep and at least 22mm (7/8") wide may be used. Any section that may be used for a mast may be used for a boom.

34. Aluminum booms must be made of alloy 6063T6 or equivalent.

35. A band 25mm (1") with the forward side located at 2559mm (8' 4 3/4") aft of the aft side of the mast (the aft side of the mast includes the sail slot and material enclosing the boltrope), will limit the length of mainsail foot. A screw or other stopper shall limit the mainsail foot so that the aftermost edge of the sail at the clew shall not be stretched beyond the foremost edge of the band.

36. Boom shall be essentially straight and shall not be tapered nor have lightening holes. The depth of the boom at either end may be reduced for access to blocks or boltrope. Only one boom may be used during a regatta unless irreparable damage has occurred.

Weight Limit

37. The minimum weight, including mast, boom, rigging, mainsheet, one whisker pole or whisker pole launching system, centerboard, rudder and tiller shall be 172.8 kgs (381 lbs).

The bare hull including deck, centerboard trunk, floorboards, flotation, hull fittings and sail away equipment shall weigh 125.2kgs (276 lbs) minimum.

The weight of this boat as outlined above is 172.8 lbs/kg

Amount of ballast 6.0 lbs/kg

Ballast location must be Marked
On Diagram on Page 3 & 4

In addition ballast up to 15 kg (33 lbs) may be permanently added in any location, subject to the requirements for Moment of Inertia and where it may be seen and it shall be attached with peened over bolts or glass cloth (See Supplement to Measurement Data Sheet for Moment of Inertia Test). Boats that do not meet the weight limit must have ballast permanently added before they can be given Measurement Certificate. Boats must be re-weighed at start of each season.

37.1 Extra weight added to compensate for the difference in weight of an aluminum centerboard and one made of SMC (see Rule 17.2) is exempted from the 15kg limitation in Rule 38.1.

38. Effective January 1, 1996, measurement certificates shall include a hull diagram showing ballast weight and location and Moment of Inertia value.

Approved Options Not Covered Elsewhere

52. Self-bailing cockpit: no restriction on method of construction.

52.1 Hiking straps: no restriction on number or location.

52.2 Tiller extension: no restriction.

52.3 Boom vang: no restriction.

52.4 Cleats for jib sheets or mainsail sheets: no restriction on number, type or location.

52.5 Jib fairleads: no restriction on type and location.

52.6 Mainsheet bridle: any type or location permitted. May be adjusted while racing.

52.7 Mainsail clew outhaul: any type permitted. May be adjusted while racing.

52.8 Sliding gooseneck: may be on track or in slot in mast. Must have some means to prevent downward movement beyond position giving maximum legal length of luff. The position of gooseneck may be changed while racing.

52.9 Floorboards are optional.

52.10 All metric measurements are taken to the nearest millimeter*. Questions must be resolved by using the customary system which is also shown, and which was used in designing the boat.

52.11 The maximum overall length of the whisker pole is 2642mm (104") and it may not extend in front of the bow of the boat or aft of the boom when not deployed. Pole launcher and retractor system using shock cord are allowed. The mast fitting from which a retractable whisker pole is launched shall not project further than the forward face of the mast.

52.12 Carbon, aramid fibers or micro-grooved film shall not be used in hull construction or major equipment. Exotic materials may be used in running rigging fittings only if commercially manufactured and readily available on the open market at prices competitive with similar fittings and equipment of non-exotic material.

52.13. No electronic devices other than timers shall be used on the boat.

Miscellaneous

52.14 Boats must carry wearable life preservers for all occupants at all times, and race committees may require wearing them when racing when they consider it necessary.

52.15 Suitable paddle or oar must be carried.

52.16 A towline of 10 meters (33') minimum length, and 6mm (1/4") minimum diameter must be carried. SCIRA makes no prescription on anchor but some local authorities may require it.

52.17 There shall be no advertising matter whatever on the outside or inside of any boat or on its sails, except as allowed by the SCIRA Event Sponsorship Policy. Any boat infringing this ruling shall not be issued or shall be subject to loss of measurement certificate.

52.18 Sliding seats, hiking boards, trapeze rigs and other artificial methods of supporting the skipper's or crew's weight to balance the boat are prohibited. This does not prevent the use of hiking straps or any kind of line or cord attached to the boat within 203 mm (8") of the top of the deck. It is permissible for the crew to hold on to the side stays.

Sentences marked * shall apply to boats, masts, booms and sails built after January 1, 2000.

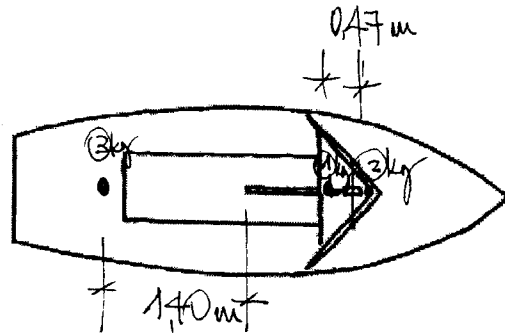

Briefly note exceptions here
(If additional explanatory
sheet is attached, check...)

MEASURERS ARE CAUTIONED TO FILL OUT THIS DATA SHEET IN FULL AND AS ACCURATELY AS POSSIBLE:
Those measurements found correct should be "circled" carefully on the drawing below, preferably with colored pencil.
If certain measurements are *NOT* within the limits shown, cover same on the drawing with an "X" and use a reference letter
or line across to your marginal note, giving the actual measurement.

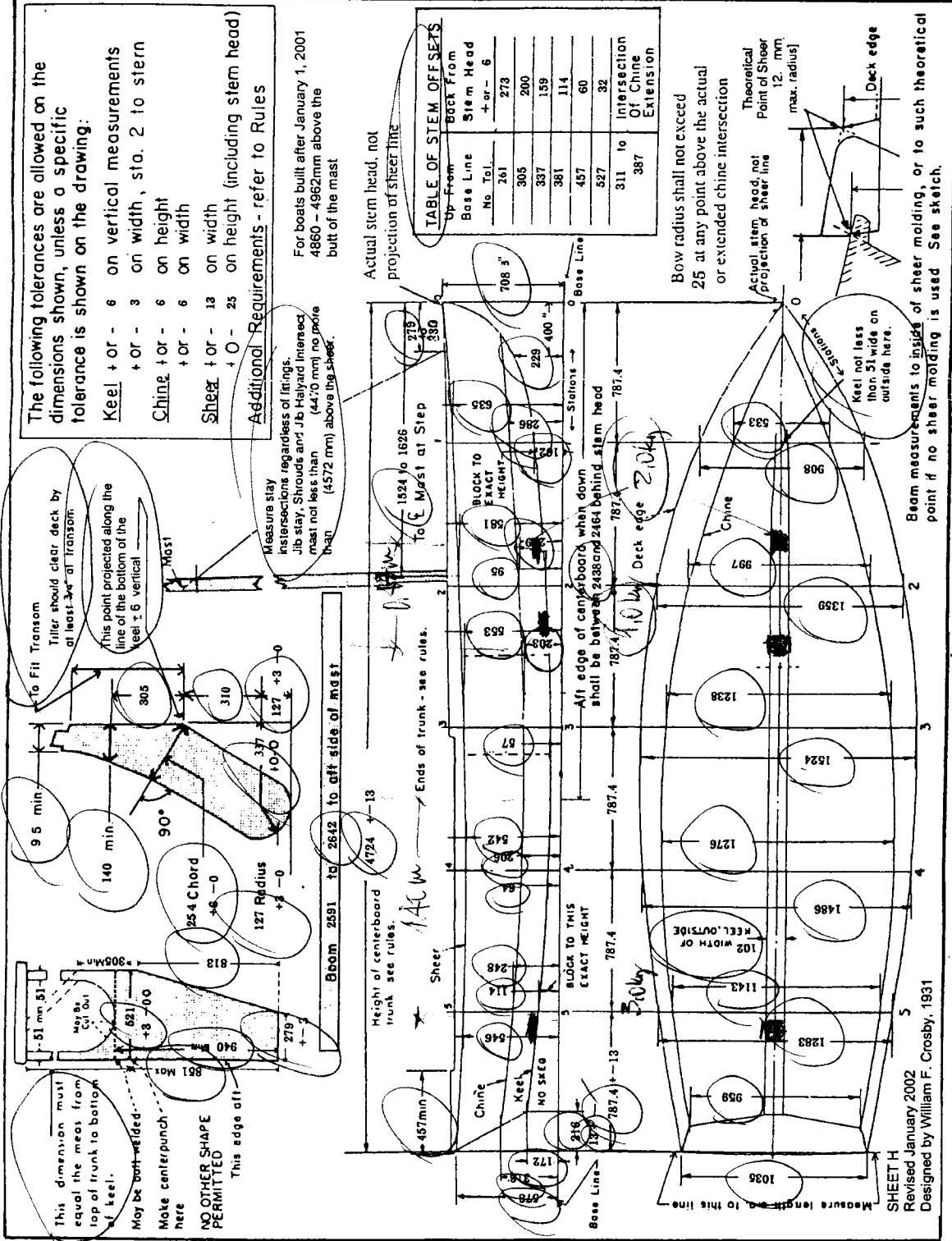

The following tolerances are allowed on the dimensions shown, unless a specific tolerance is shown on the drawing:

Keel + or - 6 on vertical measurements
+ or - 3 on width, sta. 2 to stern

Chine + or - 6 on height
+ or - 6 on width

Sheer + or - 13 on width
+ 0 - 25 on height (including stem head)

Additional Requirements - refer to Rules

For boats built after January 1, 2001
4860 - 4962mm above the
butt of the mast

Actual stem head, not projection of sheer line

Up from Base Line	Stem Head	Back From
No. Tol.	+ or -	6
261	273	
305	200	
337	159	
381	114	
457	60	
527	32	
311 to Intersection Of Chine Extension		

Bow radius shall not exceed
25 at any point above the actual
or extended chine intersection

Actual stem head, not projection of sheer line
Theoretical Point of Sheer Intersection
12 mm max. radius

Beam measurements to inside of sheer molding, or to such theoretical point if no sheer molding is used See sketch.

Divisional
Fleet, Charter No. 159

Note: The Fleet Measurer must under no circumstances give the Certificate of Measurement to the owner unless he is positive that the boat fully complies with these restrictions. If positive, the Measurer gives the Certificate to the owner and sends this Data Sheet to the Secretary.

I hereby certify that I am the official measurer of the Rio de Janeiro Divisional Fleet, Charter No. 159
I certify and affirm that I have carefully measured this boat No. 30293 to the best of my ability and that all the measurements written herein or checked by me were found to be exactly as indicated. I am ready and willing to swear to this before any accredited notary public.
(Date) 11/11/02 (Measurer's Signature) [Signature]
Recommended for Certificate (Initial) Not Recommended

SHEET H
Revised January 2002
Designed by William F. Crosby, 1931

PLEASE USE INK