

SNIPE CLASS RACING ASSOCIATION

MEASUREMENT DATA SHEET Sheet I- revised January 2009 For boats built after January 1, 2009

HULL NUMBER 30836 BUILDER DIEMER
 MODEL D# 2009 YEAR 2009
 OWNER MATEUS FIGUEIREDO COUNTRY Brazil

BARE HULL COMPLETE from certified mould INCOMPLETE
 HULL MATERIAL: WOOD FIBERGLASS *make note of*
 DECK MATERIAL: WOOD FIBERGLASS *incomplete items*

HULL WEIGHT (MIN 125KG)	<input checked="" type="checkbox"/>	MAST LENGTH (6499MM)	<input checked="" type="checkbox"/>
TOTAL WEIGHT (172.8KG)	<input checked="" type="checkbox"/>	Limiting bands & pin	<input checked="" type="checkbox"/>
BALLAST (MAX 15KG mark below)	<input checked="" type="checkbox"/>	BOOM LENGTH (2642MM from aft edge of mast)	<input checked="" type="checkbox"/>
MOI	<input checked="" type="checkbox"/>	Limiting bands	<input checked="" type="checkbox"/>
JIB FITTING (279-330 dist. from pt 0)	<input checked="" type="checkbox"/>	POLE LENGTH (2642MM)	<input checked="" type="checkbox"/>
SHROUDS (1778-1981mm dist. from pt. 0)	<input checked="" type="checkbox"/>	RUDDER DIMENSIONS	<input checked="" type="checkbox"/>
UPPER GUDGEON (410+/-3MM)	<input checked="" type="checkbox"/>	RUDDER WEIGHT (2.72kg)	<input checked="" type="checkbox"/>
LOWER GUDGEON (155 +/-3MM)	<input checked="" type="checkbox"/>	Fits the Transom (Y/N)	<input checked="" type="checkbox"/>
MAST HOLE (1494mm dist. from pt. 0)	<input checked="" type="checkbox"/>	CENTERBOARD DIMENSIONS	<input checked="" type="checkbox"/>
TRUNK HEIGHT (310 -0+3MM)	<input checked="" type="checkbox"/>	Band	<input checked="" type="checkbox"/>
		Restraining System & stoppers	<input checked="" type="checkbox"/>

Mark ballast here

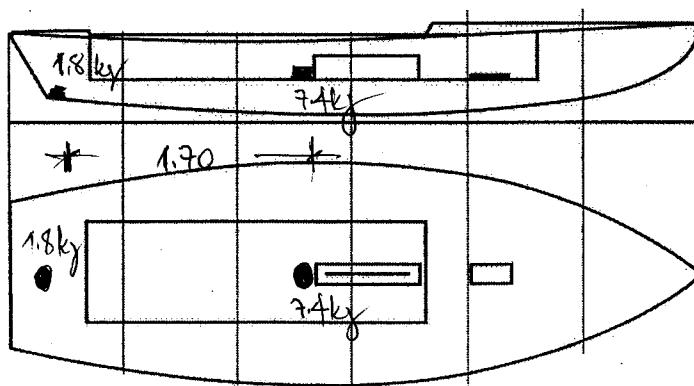

DATE MEASURED... 09/29/2009 ...
 MEASURER'S SIGNATURE [Signature]
 MEASURER'S STAMP... **01 SCIRA** ...
MEASURER
BRAZIL

NOTES:

Both pages must be completed and sent to the SCIRA office upon completion of measurement except if hull is from a certified mould.

SCIRA Measurement Check Sheet

To be used with the 80/20 true baseline measurement frame

Owner: MATEUS FIGUEIREDO Date: 09/29/2009

Hull # 30826 Builder: DIENER Material: FG

Chines Height

Station	Starboard	Port	Total	Allowable Range	Width	Allowable Range
1	424	427	851	838-864	538	527-540
2	372	376	748	724-749	994	991-1003
3	345	343	688	673-699	1233	1232-1245
4	341	349	686	680-705	1274	1270-1283
5	382	386	768	762-787	1140	1137-1149
Transom	452	454	906	902-927	855	952-965

Sheer

Station	Starboard	Port	Total	Allowable Range	Width	Allowable Range
1	770	771	1541	1499-1549	903	895-921
2	715	717	1432	1391-1441	1347	346-1372
3	688	686	1374	1333-1384	1513	1511-1537
4	666	669	1335	1321-1372	1475	1473-1499
5	670	674	1344	1321-1372	1274	1270-1295
Transom	694	695	1389	1384-1435	1023	1022-1048

Keel

	Height	Width
400mm	✓	✓
1	✓	✓
2	✓	✓
3	✓	✓
4	✓	✓
5	✓	✓
Transom	✓	✓

Rudder

Weight	2.72kg	✓
Shape		✓
Thickness		✓
Lock		✓
Keel Ext.		✓

Daggerboard

Bottom	✓
Shape	✓
Thickness	✓
Stripe	✓
Punch mark	✓
Tapers	✓

Horizontal Transom Offset 203-229 LOA 4711-4737

Weight 172.8 Ballast (lead) 9.2 kg MOI >27.6 ✓ 27.75

Mast SW

Boom

Bow

Band loc	✓
Length <6499mm	✓
Limiting pin	✓
Sheer mark	✓
Weight/bal 9.1kg	✓

Band loc 2559mm	✓
Limiting pin	✓
Max Length <2642mm	✓
Pole length <2642mm	✓

Stem height 683-708	✓
Bow radius	✓

Topside Measurements

Aft end of Trunk 2438-2464 from stem	✓	Length of daggerboard slot	✓
Top of trunk parallel to baseline	✓	Width of daggerboard slot	✓
Aft edge of trunk perpendicular to baseline	✓	Stem to mast partner >1494	✓
Keel to top of trunk 310-313 <u>313</u>	✓	Length of foredeck >1842	✓
Shroud fitting to stem 1778-1981	✓	Length of aft deck >457	✓
Mast step to sheer (vertical) 390-400	✓	Headstay to stem 279-330	✓

Measurer MATEUS FIGUEIREDO