

# SNIPE CLASS RACING ASSOCIATION

## MEASUREMENT DATA SHEET Sheet I- revised January 2009 For boats built after January 1, 2009

HULL NUMBER 30932 BUILDER DIEMED  
 MODEL D#2010 YEAR 2010  
 OWNER JOSE ROBERTO DE JESUS COUNTRY Brazil

BARE HULL  COMPLETE  from certified mould  INCOMPLETE   
 HULL MATERIAL: WOOD  FIBERGLASS  *make note of*  
 DECK MATERIAL: WOOD  FIBERGLASS  *incomplete items*

- |  |                                     |  |                                     |
|--|-------------------------------------|--|-------------------------------------|
| HULL WEIGHT (MIN 125KG)                | <input checked="" type="checkbox"/> | MAST LENGTH (6499MM)                       | <input checked="" type="checkbox"/> |
| TOTAL WEIGHT (172.8KG)                 | <input checked="" type="checkbox"/> | Limiting bands & pin                       | <input checked="" type="checkbox"/> |
| BALLAST (MAX 15KG mark below)          | <input checked="" type="checkbox"/> | BOOM LENGTH (2642MM from aft edge of mast) | <input checked="" type="checkbox"/> |
| MOI                                    | <input checked="" type="checkbox"/> | Limiting bands                             | <input checked="" type="checkbox"/> |
| JIB FITTING (279-330 dist. from pt. 0) | <input checked="" type="checkbox"/> | POLE LENGTH (2642MM)                       | <input checked="" type="checkbox"/> |
| SHROUDS (1778-1981mm dist. from pt. 0) | <input checked="" type="checkbox"/> | RUDDER DIMENSIONS                          | <input checked="" type="checkbox"/> |
| UPPER GUDGEON (410+/-3MM)              | <input checked="" type="checkbox"/> | RUDDER WEIGHT (2.72kg)                     | <input checked="" type="checkbox"/> |
| LOWER GUDGEON (155 +/-3MM)             | <input checked="" type="checkbox"/> | Fits the Transom (Y/N)                     | <input checked="" type="checkbox"/> |
| MAST HOLE (1494mm dist. from pt. 0)    | <input checked="" type="checkbox"/> | CENTERBOARD DIMENSIONS                     | <input checked="" type="checkbox"/> |
| TRUNK HEIGHT (310 -0+3MM)              | <input checked="" type="checkbox"/> | Band                                       | <input checked="" type="checkbox"/> |
|  |                                     | Restraining System & stoppers              | <input checked="" type="checkbox"/> |

Mark ballast here

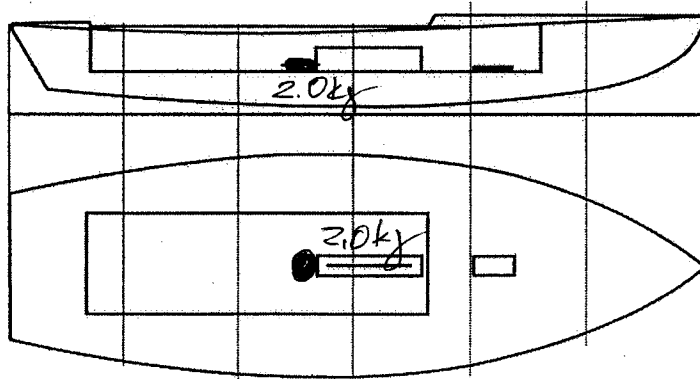

DATE MEASURED 08/27/2010  
 MEASURER'S SIGNATURE [Signature]

MEASURER'S STAMP **01 SCIRA MEASURER BRAZIL**

NOTES:

**Both pages must be completed and sent to the SCIRA office upon completion of measurement except if hull is from a certified mould.**

# SCIRA Measurement Check Sheet

To be used with the 80/20 true baseline measurement frame

Owner: JOSE ROBERTO DE JESUS Date: 08/27/2010

Hull # 30932 Builder: DIEMER Material: FG

## Chines Height

Station	Starboard	Port	Total	Allowable Range	Width	Allowable Range
1	428	423	851	838-864	533	527-540
2	375	373	748	724-749	982	991-1003
3	345	344	689	673-699	1232	1232-1245
4	343	341	684	680-705	1279	1270-1283
5	385	381	766	762-787	1138	1137-1149
Transom	455	453	908	902-927	954	952-965

## Sheer

Station	Starboard	Port	Total	Allowable Range	Width	Allowable Range
1	771	773	1544	1499-1549	920	895-921
2	714	716	1430	1391-1441	1360	346-1372
3	691	690	1381	1333-1384	1523	1511-1537
4	670	668	1338	1321-1372	1474	1473-1499
5	675	674	1349	1321-1372	1276	1270-1295
Transom	696	695	1391	1384-1435	1023	1022-1048

## Keel

	Height	Width
400mm	✓	✓
1	✓	✓
2	✓	✓
3	✓	✓
4	✓	✓
5	✓	✓
Transom	✓	✓

## Rudder

Weight	2.72kg	✓
Shape		✓
Thickness		✓
Lock		✓
Keel Ext.		✓

## Daggerboard

Bottom	✓
Shape	✓
Thickness	✓
Stripe	✓
Punch mark	✓
Tapers	✓

Horizontal Transom Offset 203-229 ✓ LOA 4711-4737 ✓

Weight 172.8 kg Mast 281 kg m<sup>2</sup>  
 Ballast (lead) 2.0 kg Boom  Bow

Band loc	✓
Length <6499mm	✓
Limiting pin	✓
Sheer mark	✓
Weight/bal 9.1kg	✓

Band loc 2559mm	✓
Limiting pin	✓
Max Length <2642mm	✓
Pole length <2642mm	✓

Stem height 683-708	✓
Bow radius	

## Topside Measurements

Aft end of Trunk 2438-2464 from stem	✓	Length of daggerboard slot	✓
Top of trunk parallel to baseline	✓	Width of daggerboard slot	✓
Aft edge of trunk perpendicular to baseline	✓	Stem to mast partner >1494	✓
Keel to top of trunk 310-313	✓	Length of foredeck >1842	✓
Shroud fitting to stem 1778-1981	✓	Length of aft deck >457	✓
Mast step to sheer (vertical) 390-400	✓	Headstay to stem 279-330	✓

Measurer M Evans