

SNIPE CLASS RACING ASSOCIATION

MEASUREMENT DATA SHEET Sheet I- revised January 2009 For boats built after January 1, 2009

HULL NUMBER 31296 BUILDER DB - MARINE ÉOLO
 MODEL DB R - 1 YEAR 2015
 OWNER Domingos Borralho COUNTRY Portugal

BARE HULL COMPLETE from certified mould INCOMPLETE
 HULL MATERIAL: WOOD FIBERGLASS *make note of*
 DECK MATERIAL: WOOD FIBERGLASS *incomplete items*

HULL WEIGHT (MIN 125KG)	<input checked="" type="checkbox"/>	MAST LENGTH (6499MM)	<input checked="" type="checkbox"/>
TOTAL WEIGHT (172.8KG)	<input checked="" type="checkbox"/>	Limiting bands & pin	<input checked="" type="checkbox"/>
BALLAST (MAX 15KG mark below)	<input checked="" type="checkbox"/>	BOOM LENGTH (2642MM from aft edge of mast)	<input checked="" type="checkbox"/>
MOI	<input checked="" type="checkbox"/>	Limiting bands	<input checked="" type="checkbox"/>
JIB FITTING (279-330 dist. from pt 0)	<input checked="" type="checkbox"/>	POLE LENGTH (2642MM)	<input checked="" type="checkbox"/>
SHROUDS (1778-1981mm dist. from pt. 0)	<input checked="" type="checkbox"/>	RUDDER DIMENSIONS	<input checked="" type="checkbox"/>
UPPER GUDGEON (410+/-3MM)	<input checked="" type="checkbox"/>	RUDDER WEIGHT (2.72kg)	<input checked="" type="checkbox"/>
LOWER GUDGEON (155 +/-3MM)	<input checked="" type="checkbox"/>	Fits the Transom (Y/N)	<input checked="" type="checkbox"/>
MAST HOLE (1494mm dist. from pt. 0)	<input checked="" type="checkbox"/>	CENTERBOARD DIMENSIONS	<input checked="" type="checkbox"/>
TRUNK HEIGHT (310 -0+3MM)	<input checked="" type="checkbox"/>	Band	<input checked="" type="checkbox"/>
		Restraining System & stoppers	<input checked="" type="checkbox"/>

Mark ballast here

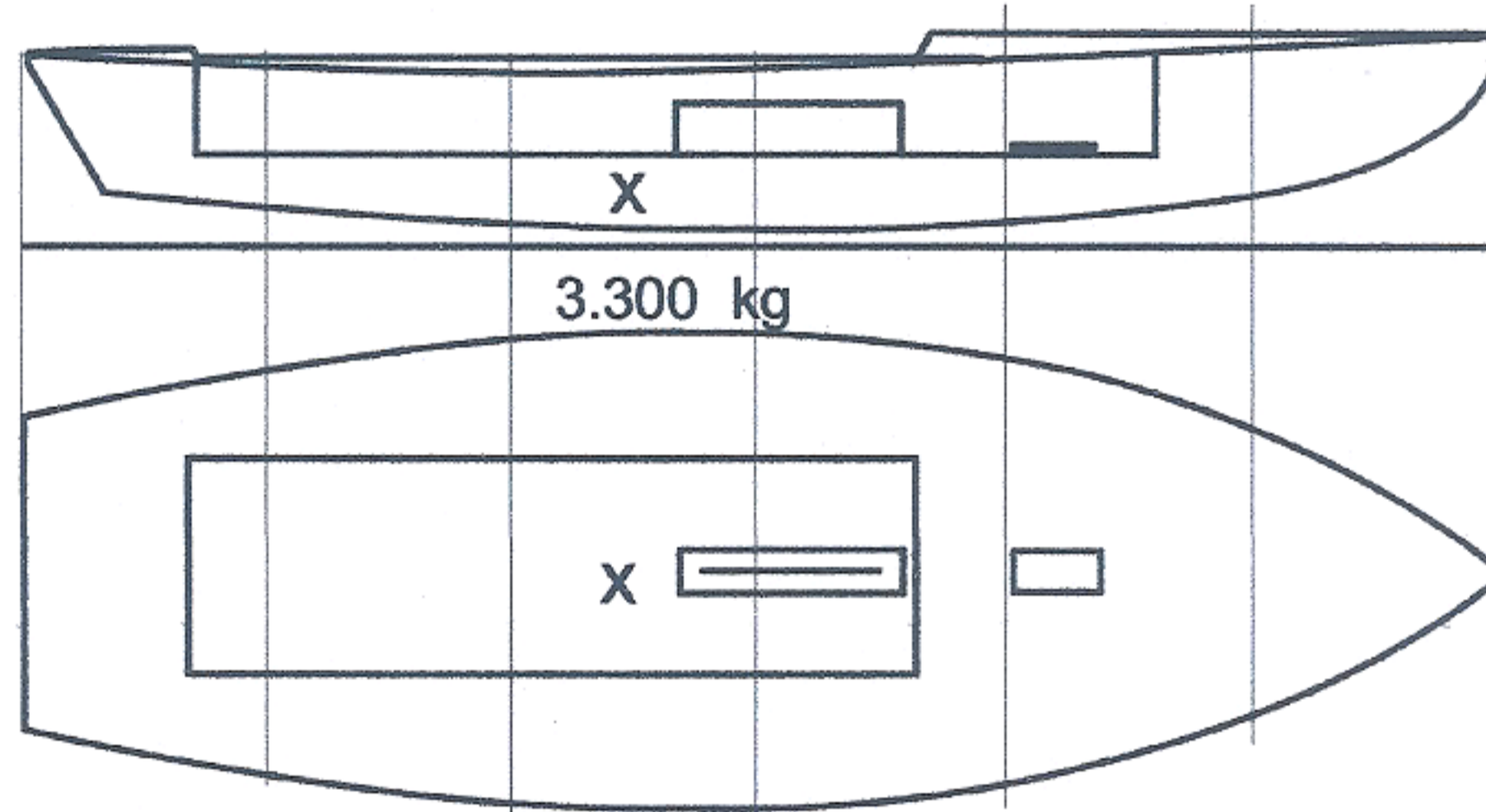

DATE MEASURED 28/01/2016 06/07/2021

MEASURER'S SIGNATURE Domingos Borralho

**01 SCIRA
MEASURER
PORTUGAL**

MEASURER'S STAMP

NOTES: NATIONAL SECRETARY: Pedro Andrade Pedro Andrade

Both pages must be completed and sent to the SCIRA office upon completion of measurement except if hull is from a certified mould.

SCIRA Measurement Check Sheet

To be used with the 80/20 true baseline measurement frame

Owner: Domingos Borralho Date: 06/07/2021

Hull # 31296 Builder: DB Marine Material: F.G.

Chines Height

Station	Starboard	Port	Total	Allowable Range	Width	Allowable Range
1				838-864		527-540
2				724-749		991-1003
3				673-699		1232-1245
4				680-705		1270-1283
5				762-787		1137-1149
Transom				902-927		952-965

Sheer

Station	Starboard	Port	Total	Allowable Range	Width	Allowable Range
1				1499-1549		895-921
2				1391-1441		346-1372
3				1333-1384		1511-1537
4				1321-1372		1473-1499
5				1321-1372		1270-1295
Transom				1384-1435		1022-1048

Keel

	Height	Width
400mm		
1		
2		
3		
4		
5		
Transom		

Rudder

Weight	2,8 kg
2.72kg	
Shape	x
Thickness	x
Lock	x
Keel Ext.	x

Daggerboard

Bottom	x
Shape	x
Thickness	x
Stripe	x
Punch mark	x
Tapers	x

Horizontal Transom Offset 203-229 LOA 4711-4737

Weight 172,810 kg Ballast (lead) 3,300 kg MOI >27.6 28.22

Mast

Band loc	x
Length <6499mm	x
Limiting pin	x
Sheer mark	x
Weight/bal 9.1kg	x

Boom

Band loc 2559mm	x
Limiting pin	x
Max Length <2642mm	x
Pole length <2642mm	x

Bow

Stem height 683-708	
Bow radius	

Topside Measurements

Aft end of Trunk 2438-2464 from stem	x	Length of daggerboard slot	x
Top of trunk parallel to baseline	x	Width of daggerboard slot	x
Aft edge of trunk perpendicular to baseline	x	Stem to mast partner >1494	x
Keel to top of trunk 310-313	x	Length of foredeck >1842	x
Shroud fitting to stem 1778-1981	x	Length of aft deck >457	x
Mast step to sheer (vertical) 390-400	x	Headstay to stem 279-330	x

Measurer Domingos Borralho Pedro Andrade (National Secretary)

Pedro Andrade

SNIPE CLASS RACING ASSOCIATION

MEASUREMENT DATA SHEET Sheet I- revised January 2009 For boats built after January 1, 2009

HULL NUMBER 31296 BUILDER DB - MARINE ÉOLO
 MODEL DB R - 1 YEAR 2015
 OWNER Domingos Borralho COUNTRY Portugal

BARE HULL COMPLETE from certified mould INCOMPLETE
 HULL MATERIAL: WOOD FIBERGLASS *make note of*
 DECK MATERIAL: WOOD FIBERGLASS *incomplete items*

HULL WEIGHT (MIN 125KG)	<input checked="" type="checkbox"/>	MAST LENGTH (6499MM)	<input checked="" type="checkbox"/>
TOTAL WEIGHT (172.8KG)	<input checked="" type="checkbox"/>	Limiting bands & pin	<input checked="" type="checkbox"/>
BALLAST (MAX 15KG mark below)	<input checked="" type="checkbox"/>	BOOM LENGTH (2642MM from aft edge of mast)	<input checked="" type="checkbox"/>
MOI	<input checked="" type="checkbox"/>	Limiting bands	<input checked="" type="checkbox"/>
JIB FITTING (279-330 dist. from pt 0)	<input checked="" type="checkbox"/>	POLE LENGTH (2642MM)	<input checked="" type="checkbox"/>
SHROUDS (1778-1981mm dist. from pt. 0)	<input checked="" type="checkbox"/>	RUDDER DIMENSIONS	<input checked="" type="checkbox"/>
UPPER GUDGEON (410+/-3MM)	<input checked="" type="checkbox"/>	RUDDER WEIGHT (2.72kg)	<input checked="" type="checkbox"/>
LOWER GUDGEON (155 +/-3MM)	<input checked="" type="checkbox"/>	Fits the Transom (Y/N)	<input checked="" type="checkbox"/>
MAST HOLE (1494mm dist. from pt. 0)	<input checked="" type="checkbox"/>	CENTERBOARD DIMENSIONS	<input checked="" type="checkbox"/>
TRUNK HEIGHT (310 -0+3MM)	<input checked="" type="checkbox"/>	Band	<input checked="" type="checkbox"/>
		Restraining System & stoppers	<input checked="" type="checkbox"/>

Mark ballast here

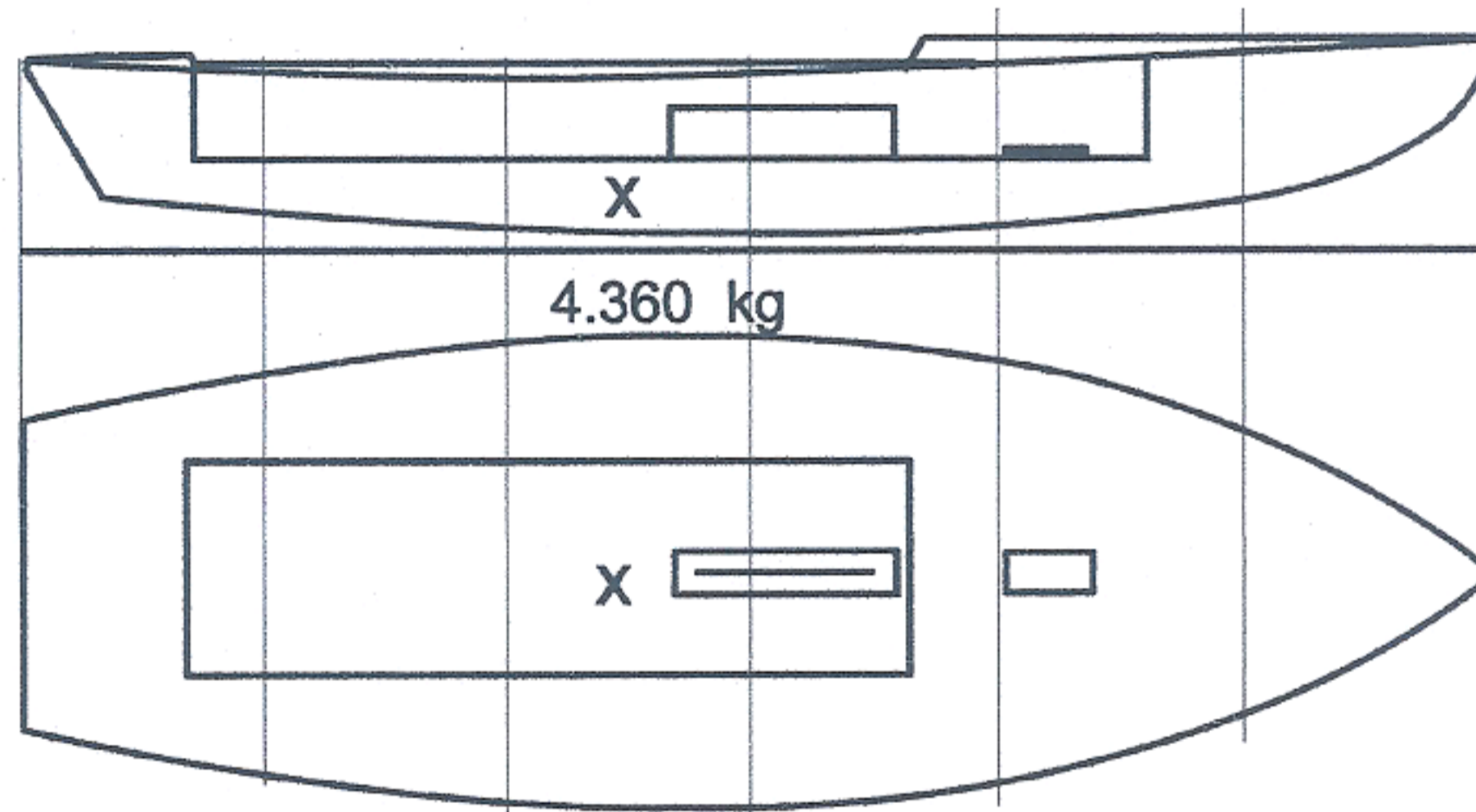

DATE MEASURED 28/01/2016 06/07/2021

MEASURER'S SIGNATURE Domingos Borralho

01 SCIRA
MEASURER
PORTUGAL

MEASURER'S STAMP

NOTES: NATIONAL SECRETARY: Pedro Andrade Pedro Andrade

Both pages must be completed and sent to the SCIRA office upon completion of measurement except if hull is from a certified mould.

SCIRA Measurement Check Sheet

To be used with the 80/20 true baseline measurement frame

Owner: Domingos Borralho Date: 06/07/2021

Hull # 31296 Builder: DB Marine Material: F.G.

Chines Height

Station	Starboard	Port	Total	Allowable Range	Width	Allowable Range
1				838-864		527-540
2				724-749		991-1003
3				673-699		1232-1245
4				680-705		1270-1283
5				762-787		1137-1149
Transom				902-927		952-965

Sheer

Station	Starboard	Port	Total	Allowable Range	Width	Allowable Range
1				1499-1549		895-921
2				1391-1441		346-1372
3				1333-1384		1511-1537
4				1321-1372		1473-1499
5				1321-1372		1270-1295
Transom				1384-1435		1022-1048

Keel

	Height	Width
400mm		
1		
2		
3		
4		
5		
Transom		

Rudder

Weight	2,8 kg
2.72kg	
Shape	x
Thickness	x
Lock	x
Keel Ext.	x

Daggerboard

Bottom	x
Shape	x
Thickness	x
Stripe	x
Punch mark	x
Tapers	x

Horizontal Transom Offset 203-229 LOA 4711-4737

Weight 172,810 kg Ballast (lead) 3,360 kg MOI >27.6 28.22

Mast

Band loc	x
Length <6499mm	x
Limiting pin	x
Sheer mark	x
Weight/bal 9.1kg	x

Boom

Band loc 2559mm	x
Limiting pin	x
Max Length <2642mm	x
Pole length <2642mm	x

Bow

Stem height 683-708	
Bow radius	

Topside Measurements

Aft end of Trunk 2438-2464 from stem	x	Length of daggerboard slot	x
Top of trunk parallel to baseline	x	Width of daggerboard slot	x
Aft edge of trunk perpendicular to baseline	x	Stem to mast partner >1494	x
Keel to top of trunk 310-313	x	Length of foredeck >1842	x
Shroud fitting to stem 1778-1981	x	Length of aft deck >457	x
Mast step to sheer (vertical) 390-400	x	Headstay to stem 279-330	x

Measurer Domingos Borralho

Pedro Andrade (National Secretary)