

SNIFE CLASS RACING ASSOCIATION

MEASUREMENT DATA SHEET FOR CERTIFIED BOATS

Revised February 2019

This page to be used for all boats. For measurements in *Italic* refer to the Class Rules

HULL NUMBER	31605	BUILDER	Tsujiro
MODEL	Tsujiro	YEAR OF MANUFACTURE	2019
OWNER	Wakasu Yacht Training Center	COUNTRY	Japan

BARE HULL	<input type="checkbox"/>	COMPLETE	<input type="checkbox"/>	INCOMPLETE	<input type="checkbox"/>
HULL MATERIAL: WOOD	<input type="checkbox"/>	FIBERGLASS	<input checked="" type="checkbox"/>	make note of incomplete items filling the cells with NO	
DECK MATERIAL: WOOD	<input type="checkbox"/>	FIBERGLASS	<input checked="" type="checkbox"/>		
FROM CERTIFIED MOULD	<input type="checkbox"/>				

HULL WEIGHT (min 125kg)	127.7kg	MAST LENGTH (Rules C.9.2, F.3.4)	9.42kg
TOTAL WEIGHT (min 172.8kg)	172.8kg	Limiting marks & pin	<input checked="" type="checkbox"/>
CORRECTOR WEIGHTS (max 15kg)	7.5kg	Corrector weights (max 100gr)	<input checked="" type="checkbox"/>
MOI	271kg	BOOM LENGTH (max 2642mm)	2642mm
Spring set #	#95	Limiting marks & pin	<input checked="" type="checkbox"/>
JIB FITTING	285mm	POLE LENGTH (max 2642mm)	2642mm
(279-330mm hor. From Hull Datum Point)		RUDDER DIMENSIONS	<input checked="" type="checkbox"/>
max 45mm vert. above sheerline)		Weight (min. 2.72kg)	3.35kg
SHROUDS (1778-1981mm from HDP)	1780mm	Corrector weights (Rule C.8.5)	—
MAST HOLE (min 1494-mm from HDP)	1500mm	Parallel to transom (tolerance 2mm)	<input checked="" type="checkbox"/>
UPPER GUDGEON (Rule D.2.3)	410mm	DAGGERBOARD DIMENSIONS	<input checked="" type="checkbox"/>
LOWER GUDGEON (Rule D.2.3)	151mm	Band	<input checked="" type="checkbox"/>
GUDGEONS DIAMETER (Rule D.2.3)	8mm	Safety line (max 610mm long)	<input checked="" type="checkbox"/>
		Restraining system (hooks or tablet)	<input checked="" type="checkbox"/>

Insert the **actual** measurement in the cells marked as

Mark corrector weights position and amount below. Data to be copied on the Official Snipe Label

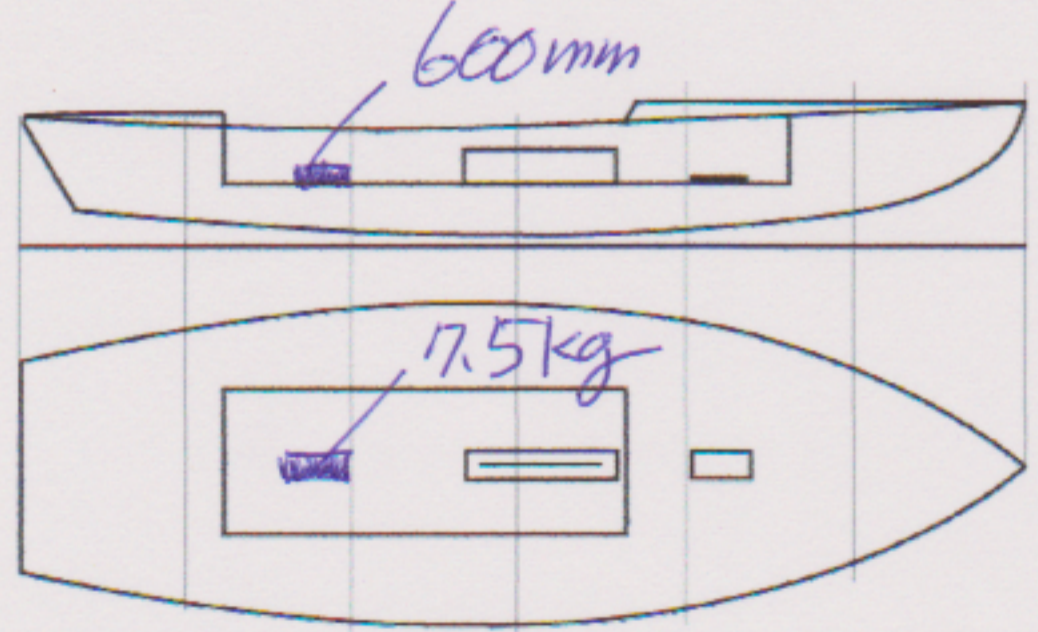

Boom = Factory Zero
Mast = Factory Zero



DATE MEASURED 28/10/2019 MEASURER'S STAMP

MEASURER'S NAME Kuniko Yamada

NOTES:

04 SCIRA
MEASURER
JAPAN