

SNIFE CLASS RACING ASSOCIATION

MEASUREMENT DATA SHEET FOR CERTIFIED BOATS

Revised February 2019

This page to be used for all boats. For measurements in Italic refer to the Class Rules

HULL NUMBER	316017	BUILDER	Tsujiido
MODEL	Tsujiido	YEAR OF MANUFACTURE	2019
OWNER	Wakasu Yacht Training Center	COUNTRY	Japan

BARE HULL	<input type="checkbox"/>	COMPLETE	<input checked="" type="checkbox"/>	INCOMPLETE	<input type="checkbox"/>
HULL MATERIAL: WOOD	<input type="checkbox"/>	FIBERGLASS	<input checked="" type="checkbox"/>	make note of	
DECK MATERIAL: WOOD	<input type="checkbox"/>	FIBERGLASS	<input checked="" type="checkbox"/>	incomplete items	
FROM CERTIFIED MOULD	<input type="checkbox"/>			filling the cells with NO	

HULL WEIGHT (min 125kg)	126.85kg	MAST LENGTH (Rules C.9.2, F.3.4)	9.4kg
TOTAL WEIGHT (min 172.8kg)	172.8kg	Limiting marks & pin	<input checked="" type="checkbox"/>
CORRECTOR WEIGHTS (max 15kg)	8.65kg	Corrector weights (max 100gr)	<input type="checkbox"/>
MOI	271kg	BOOM LENGTH (max 2642mm)	2641mm
Spring set #	H95	Limiting marks & pin	<input checked="" type="checkbox"/>
JIB FITTING	285mm	POLE LENGTH (max 2642mm)	2642mm
(279-330mm hor. From Hull Datum Point)		RUDDER DIMENSIONS	<input checked="" type="checkbox"/>
max 45mm vert. above sheerline)		Weight (min. 2.72kg)	3.95kg
SHROUDS (1778-1981mm from HDP)	1780mm	Corrector weights (Rule C.8.5)	<input type="checkbox"/>
MAST HOLE (min 1494-mm from HDP)	1500mm	Parallel to transom (tolerance 2mm)	<input checked="" type="checkbox"/>
UPPER GUDGEON (Rule D.2.3)	413mm	DAGGERBOARD DIMENSIONS	<input checked="" type="checkbox"/>
LOWER GUDGEON (Rule D.2.3)	1517mm	Band	<input checked="" type="checkbox"/>
GUDGEONS DIAMETER (Rule D.2.3)	8mm	Safety line (max 610mm long)	<input checked="" type="checkbox"/>
		Restraining system (hooks or tablet)	<input checked="" type="checkbox"/>

Insert the **actual** measurement in the cells marked as

Mark corrector weights position and amount below. Data to be copied on the Official Snipe Label

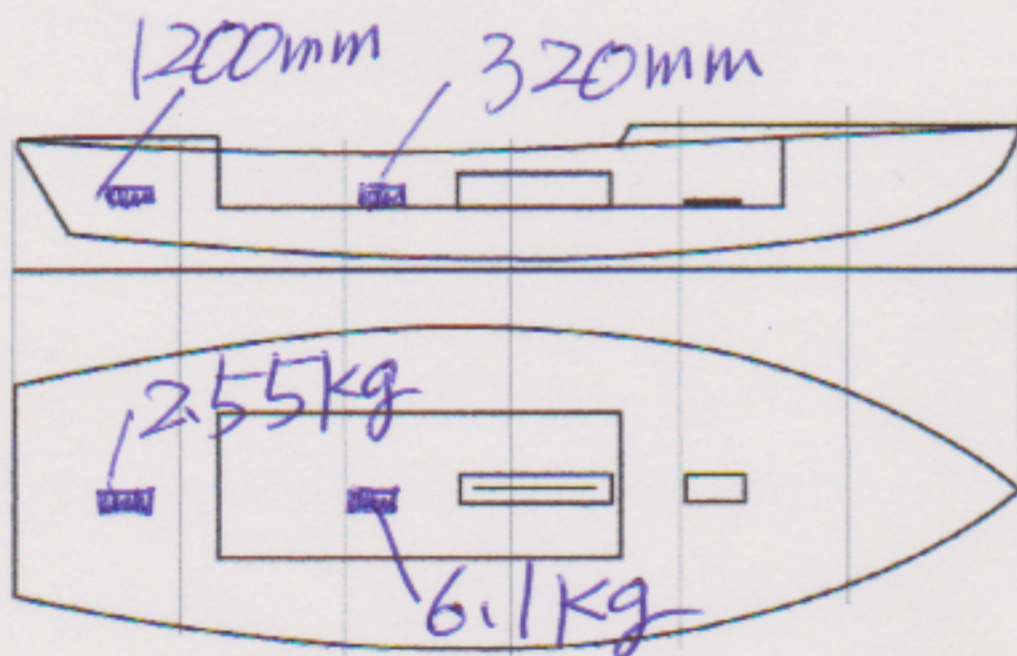

Boom = Factory Zero
Mast = Factory Zero



DATE MEASURED 29/10/2019 MEASURER'S STAMP

MEASURER'S NAME Kunitiko Yamada

NOTES:

04 SCIRA
MEASURER
JAPAN