

SNIFE CLASS RACING ASSOCIATION

MEASUREMENT DATA SHEET

Revised February 2019

This page to be used for all boats. *For measurements in Italic refer to the Class Rules*

HULL NUMBER	31608	BUILDER	DIEMER
MODEL	G4	YEAR OF MANUFACTURE	2019
OWNER	FABIO BOCCA	COUNTRY	Brazil

BARE HULL	<input type="checkbox"/>	COMPLETE	<input checked="" type="checkbox"/>	INCOMPLETE	<input type="checkbox"/>
HULL MATERIAL: WOOD	<input type="checkbox"/>	FIBERGLASS	<input checked="" type="checkbox"/>	make note of	
DECK MATERIAL: WOOD	<input type="checkbox"/>	FIBERGLASS	<input checked="" type="checkbox"/>	incomplete items	
FROM CERTIFIED MOULD	<input checked="" type="checkbox"/>			filling the cells with NO	

HULL WEIGHT (min 125kg)	128,0	MAST LENGTH (Rules C.9.2, F.3.4)	6409
TOTAL WEIGHT (min 172.8kg)	172,8	Limiting marks & pin	<input checked="" type="checkbox"/>
CORRECTOR WEIGHTS (max 15kg)	8,5	Corrector weights (max 100gr)	-
MOI	27,62	BOOM LENGTH (max 2642mm)	2642
Spring set #	94	Limiting marks & pin	<input checked="" type="checkbox"/>
JIB FITTING	<input checked="" type="checkbox"/>	POLE LENGTH (max 2642mm)	2642
(279-300mm hor. From Hull Datum Point)		RUDDER DIMENSIONS	<input checked="" type="checkbox"/>
max 45mm vert. above sheerline)		Weight (min. 2.72kg)	3,1
SHROUDS (1778-1981mm from HDP)	1790	Corrector weights (Rule C.8.5)	-
MAST HOLE (min 1494-mm from HDP)	1494	Parallel to transom (tolerance 2mm)	<input checked="" type="checkbox"/>
UPPER GUDGEON (Rule D.2.3)	410	DAGGERBOARD DIMENSIONS	<input checked="" type="checkbox"/>
LOWER GUDGEON (Rule D.2.3)	195	Band	<input checked="" type="checkbox"/>
GUDGEONS DIAMETER (Rule D.2.3)	8	Safety line (max 610mm long)	<input checked="" type="checkbox"/>
		Restraining system (hooks or tablet)	<input checked="" type="checkbox"/>

Insert the **actual** measurement in the cells marked as

Mark corrector weights position and amount below. Data to be copied on the Official Snipe Label

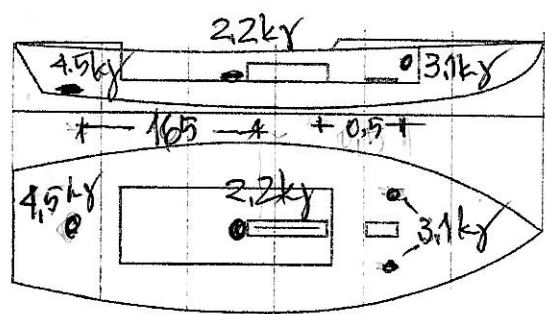

DATE MEASURED 07/18/2019 MEASURER'S STAMP

MEASURER'S NAME MARIO TAVARES

NOTES:

Keel				
Station	Height		Width	
	Actual	Allowable Range	Actual	Allowable Range
400mm	✓	223-235	✓	
1	✓	162	✓	Min 51
2	✓	89-101	✓	99-105
3	✓	51-63	✓	99-105
4	✓	58-70	✓	99-105
5	✓	114	✓	99-105
Transom	✓	166-168	✓	99-105

Stem Offset		
up from baseline	back from HDP	Actual
267	267-279	✓
305	194-206	✓
337	153-165	✓
381	108-120	✓
457	54-66	✓
527	26-38	✓
311 to 387	intersection of chine extension	

Miscellaneous					
Measurement	Actual	Allowable Range	Measurement	Actual	Allowable Range
LOA	✓	4711-4737	Chine radius at st. 1		Max 19
Horizontal transom offset	✓	203-229	Chine radius st. 2 to transom	✓	Max 3
Hull Datum Point height	✓	683-708	Deck height	✓	Max 127
Bow radius	-	Max 25			

Topside Measurements					
Measurement	Actual	Allowable Range	Measurement	Actual	Allowable Range
Aft end of dagg. slot from Hull datum point	✓	2438-2464	Mast step to sheer (vertical)	✓	390-400
Top of case parallel to baseline	✓	tolerance 2mm	Mast hole in the deck	✓	Max256x76
Aft edge of slot perpendicular to baseline	✓	tolerance 2mm	Length of foredeck	✓	Min 1842
Forward edge of slot perpendicular to baseline	✓	tolerance 6mm	Length of aft deck	✓	Min 457
Keel to top of daggerboard case	✓	310-313	Sheer strikes	✓	Max 32
Length of daggerboard slot	✓	Max 546	Gunwale radius	✓	Max 12
Width of daggerboard slot	✓	Max 13	Splashboard	✓	Min 51 x 610

Measurer

Stamp nr.

SCIRA Measurement Data Sheet

To be used with the 80/20 true baseline measurement frame

For boats built from January 1st, 2018. For older boats use the MDS in force in the year of manufacturing

Owner Fabio Bodra Date 07/19/2019
 Hull 31608 Builder Diemer Material FG

NEW MOULD: FIRST OR OF 5 CERTIFICATION RENEW Y/N

DO NOT COMPLETE IF FROM A CERTIFIED MOULD

Chine						
	Height				Width	
Station	Starboard	Port	Total	Allowable Range	Actual	Allowable Range
1				838-864		527-540
2				724-749		991-1003
3				673-699		1232-1245
4				680-705		1270-1283
5				762-787		1137-1149
Transom				902-927		952-965

Sheer						
	Height				Width	
Station	Starboard	Port	Total	Allowable Range	Actual	Allowable Range
1				1499-1549		895-921
2				1391-1441		1346-1372
3				1333-1384		1511-1537
4				1321-1372		1473-1499
5				1321-1372		1270-1295
Transom				1384-1435		1022-1048