

# SNIPE CLASS RACING ASSOCIATION

## MEASUREMENT DATA SHEET FOR CERTIFIED BOATS

Revised February 2019

This page to be used for all boats. For measurements in *Italic* refer to the Class Rules

HULL NUMBER	31609	BUILDER	Tsujido
MODEL	Tsujido	YEAR OF MANUFACTURE	2019
OWNER	Wakasu yacht training center	COUNTRY	Japan

BARE HULL	<input type="checkbox"/>	COMPLETE	<input type="checkbox"/>	INCOMPLETE	<input type="checkbox"/>
HULL MATERIAL: WOOD	<input type="checkbox"/>	FIBERGLASS	<input type="checkbox"/>	make note of incomplete items filling the cells with <b>NO</b>	
DECK MATERIAL: WOOD	<input type="checkbox"/>	FIBERGLASS	<input type="checkbox"/>		
FROM CERTIFIED MOULD	<input type="checkbox"/>				

HULL WEIGHT (min 125kg)	127.65kg	MAST LENGTH (Rules C.9.2, F.3.4)	9.42kg
TOTAL WEIGHT (min 172.8kg)	172.8kg	Limiting marks & pin	✓
CORRECTOR WEIGHTS (max 15kg)	7.85kg	Corrector weights (max 100gr)	—
MOI	271kg	BOOM LENGTH (max 2642mm)	2642mm
Spring set #	#95	Limiting marks & pin	✓
JIB FITTING	285mm	POLE LENGTH (max 2642mm)	2642mm
(279-330mm hor. From Hull Datum Point)		RUDDER DIMENSIONS	✓
max 45mm vert. above sheerline)		Weight (min. 2.72kg)	3.45kg
SHROUDS (1778-1981mm from HDP)	1780mm	Corrector weights (Rule C.8.5)	—
MAST HOLE (min 1494-mm from HDP)	1500mm	Parallel to transom (tolerance 2mm)	✓
UPPER GUDGEON (Rule D.2.3)	440mm	DAGGERBOARD DIMENSIONS	✓
LOWER GUDGEON (Rule D.2.3)	151mm	Band	✓
GUDGEONS DIAMETER (Rule D.2.3)	8mm	Safety line (max 610mm long)	✓
		Restraining system (hooks or tablet)	✓

Insert the **actual** measurement in the cells marked as

Mark corrector weights position and amount below. Data to be copied on the Official Snipe Label

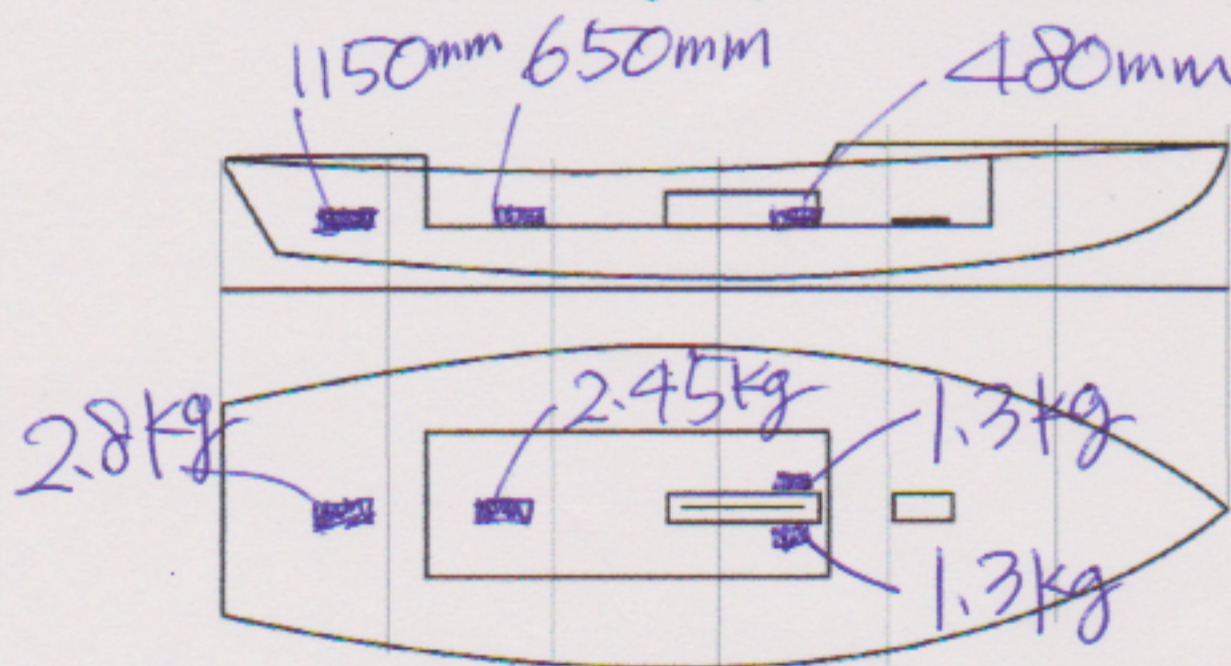

Boom = Factory Zero  
Mast = Factory Zero

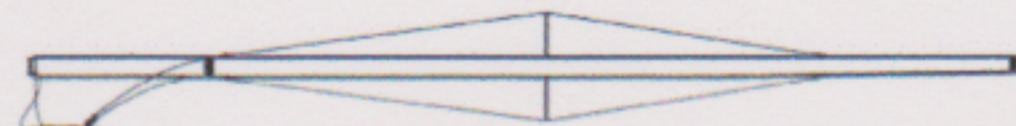

DATE MEASURED 29/10/2019 MEASURER'S STAMP

MEASURER'S NAME Kuniko Yamada

NOTES:

**04 SCIRA**  
**MEASURER**  
**JAPAN**