

SNIFE CLASS RACING ASSOCIATION

MEASUREMENT DATA SHEET FOR CERTIFIED BOATS

Revised February 2019

This page to be used for all boats. For measurements in Italic refer to the Class Rules

HULL NUMBER	31612	BUILDER	ZELTIC
MODEL	ZELTIC	YEAR OF MANUFACTURE	2019
OWNER	LUIS PESSANHA	COUNTRY	POR

BARE HULL	<input type="checkbox"/>	COMPLETE	<input checked="" type="checkbox"/>	INCOMPLETE	<input type="checkbox"/>
HULL MATERIAL: WOOD	<input type="checkbox"/>	FIBERGLASS	<input checked="" type="checkbox"/>	make note of	
DECK MATERIAL: WOOD	<input type="checkbox"/>	FIBERGLASS	<input checked="" type="checkbox"/>	incomplete items	
FROM CERTIFIED MOULD	<input checked="" type="checkbox"/>			filling the cells with NO	

HULL WEIGHT (min 125kg)	133.6	MAST LENGTH (Rules C.9.2, F.3.4)	6499
TOTAL WEIGHT (min 172.8kg)	172.8	Limiting marks & pin	OK
CORRECTOR WEIGHTS (max 15kg)	7.5	Corrector weights (max 100gr)	0
MOI kg·m²	271.3	BOOM LENGTH (max 2642mm)	2587
Spring set #	130	Limiting marks & pin	OK
JIB FITTING	OK/280	POLE LENGTH (max 2642mm)	2642
(279-300mm hor. From Hull Datum Point)		RUDDER DIMENSIONS	OK
max 45mm vert. above sheerline)		Weight (min. 2.72kg)	3.1
SHROUDS (1778-1981mm from HDP)	1778	Corrector weights (Rule C.8.5)	0
MAST HOLE (min 1494-mm from HDP)	1494	Parallel to transom (tolerance 2mm)	OK
UPPER GUDGEON (Rule D.2.3)	410	DAGGERBOARD DIMENSIONS	OK
LOWER GUDGEON (Rule D.2.3)	155	Band	OK
GUDGEONS DIAMETER (Rule D.2.3)	8.1	Safety line (max 610mm long)	610
		Restraining system (hooks or tablet)	OK

Insert the **actual** measurement in the cells marked as

Mark corrector weights position and amount below. Data to be copied on the Official Snipe Label

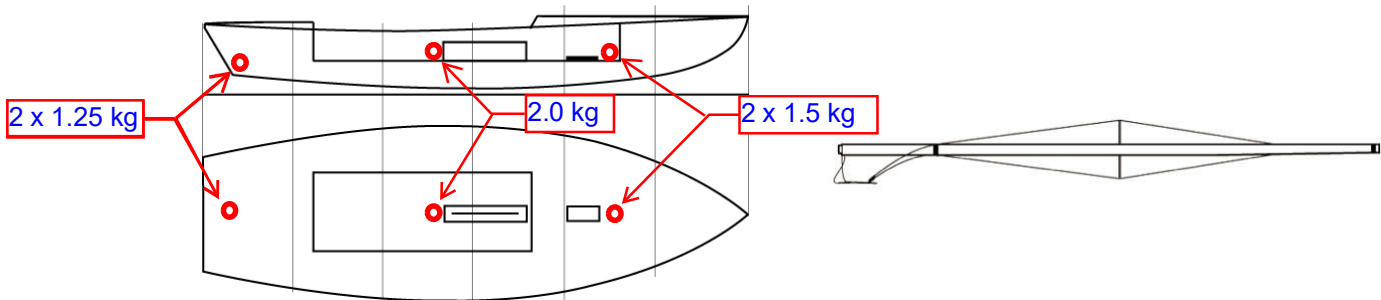

DATE MEASURED 1st Nov 2019 MEASURER'S STAMP

MEASURER'S NAME Fernando Tajuelo

NOTES:

03 SCIRA MEASURER SPAIN

Complies mast hole distance with a 11 mm thick plate at the front of moulded mast hole.