

SNIFE CLASS RACING ASSOCIATION

MEASUREMENT DATA SHEET FOR CERTIFIED BOATS

Revised February 2019

This page to be used for all boats. For measurements in Italic refer to the Class Rules

HULL NUMBER	31619	BUILDER	Tsujiido
MODEL	Tsujiido	YEAR OF MANUFACTURE	2020
OWNER	KAGAWA UNIV.	COUNTRY	Japan

BARE HULL	<input type="checkbox"/>	COMPLETE	<input checked="" type="checkbox"/>	INCOMPLETE	<input type="checkbox"/>
HULL MATERIAL: WOOD	<input type="checkbox"/>	FIBERGLASS	<input checked="" type="checkbox"/>	make note of	
DECK MATERIAL: WOOD	<input type="checkbox"/>	FIBERGLASS	<input checked="" type="checkbox"/>	incomplete items	
FROM CERTIFIED MOULD	<input type="checkbox"/>			filling the cells with NO	

HULL WEIGHT (min 125kg)	125.2	MAST LENGTH (Rules C.9.2, F.3.4)	914
TOTAL WEIGHT (min 172.8kg)	172.8	Limiting marks & pin	<input checked="" type="checkbox"/>
CORRECTOR WEIGHTS (max 15kg)	11.25	Corrector weigths (max 100gr)	0
MOI	271	BOOM LENGTH (max 2642mm)	2600
Spring set #	#95	Limiting marks & pin	<input checked="" type="checkbox"/>
JIB FITTING	285	POLE LENGTH (max 2642mm)	2635
(279-330mm hor. From Hull Datum Point)		RUDDER DIMENSIONS	<input checked="" type="checkbox"/>
max 45mm vert. above sheerline)		Weight (min. 2.72kg)	3.25
SHROUDS (1778-1981mm from HDP)	1779	Corrector weigths (Rule C.8.5)	0
MAST HOLE (min 1494-mm from HDP)	1495	Parallel to transom (tolerance 2mm)	<input checked="" type="checkbox"/>
UPPER GUDGEON (Rule D.2.3)	411	DAGGERBOARD DIMENSIONS	<input checked="" type="checkbox"/>
LOWER GUDGEON (Rule D.2.3)	151	Band	<input checked="" type="checkbox"/>
GUDGEONS DIAMETER (Rule D.2.3)	8	Safety line (max 610mm long)	<input checked="" type="checkbox"/>
		Restraining system (hooks or tablet)	<input checked="" type="checkbox"/>

Insert the **actual** measurement in the cells marked as

Mark corrector weights position and amount below. Data to be copied on the Official Snipe Label

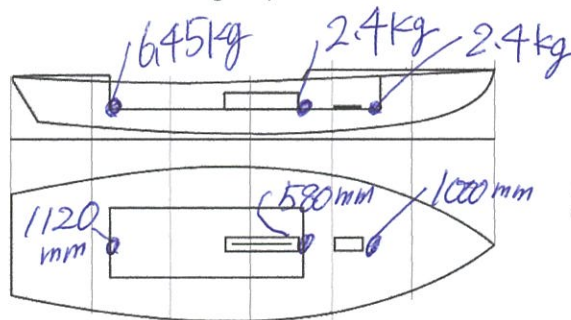

Boom: Factory Zero
Mast: Factory Zero

DATE MEASURED 3/Feb./2020 MEASURER'S STAMP

04 SCIRA
MEASURER
JAPAN

MEASURER'S NAME Kuniko Yamada

NOTES: