

# SNIFE CLASS RACING ASSOCIATION

## MEASUREMENT DATA SHEET FOR CERTIFIED BOATS

Revised February 2019

This page to be used for all boats. For measurements in *Italic* refer to the Class Rules

HULL NUMBER 31697 BUILDER Persson Marine Japan  
 MODEL NINJA II YEAR OF MANUFACTURE 2021  
 OWNER Shonan Sunny Side Marina COUNTRY Japan  
Co. Ltd

BARE HULL  COMPLETE  INCOMPLETE   
 HULL MATERIAL: WOOD  FIBERGLASS  make note of  
 DECK MATERIAL: WOOD  FIBERGLASS  incomplete items  
 FROM CERTIFIED MOULD  filling the cells with **NO**

HULL WEIGHT (min 125kg)	<u>127.94</u>	MAST LENGTH (Rules C.9.2, F.3.4)	<u>6499</u>
TOTAL WEIGHT (min 172.8kg)	<u>172.8</u>	Limiting marks & pin	<input checked="" type="checkbox"/>
CORRECTOR WEIGHTS (max 15kg)	<u>3.7</u>	Corrector weights (max 100gr)	<input checked="" type="checkbox"/>
MOI	<u>277</u>	BOOM LENGTH (max 2642mm)	<u>2641</u>
Spring set #	<u>H90</u>	Limiting marks & pin	<input checked="" type="checkbox"/>
JIB FITTING	<u>282</u>	POLE LENGTH (max 2642mm)	<u>2635</u>
(279-330mm hor. From Hull Datum Point)		RUDDER DIMENSIONS	<input checked="" type="checkbox"/>
max 45mm vert. above sheerline)		Weight (min. 2.72kg)	<u>2.78</u>
SHROUDS (1778-1981mm from HDP)	<u>1788</u>	Corrector weights (Rule C.8.5)	<u>0</u>
MAST HOLE (min 1494-mm from HDP)	<u>1494</u>	Parallel to transom (tolerance 2mm)	<input checked="" type="checkbox"/>
UPPER GUDGEON (Rule D.2.3)	<u>410</u>	DAGGERBOARD DIMENSIONS	<input checked="" type="checkbox"/>
LOWER GUDGEON (Rule D.2.3)	<u>155</u>	Band	<input checked="" type="checkbox"/>
GUDGEONS DIAMETER (Rule D.2.3)	<u>8</u>	Safety line (max 610mm long)	<input checked="" type="checkbox"/>
		Restraining system (hooks or tablet)	<input checked="" type="checkbox"/>

Insert the **actual** measurement in the cells marked as

Mark corrector weights position and amount below. Data to be copied on the Official Snipe Label

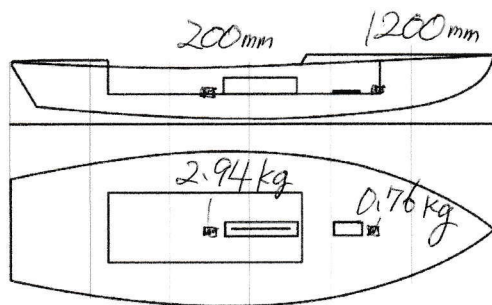

Mast: Sidewinder  
 Boom: Factory zero

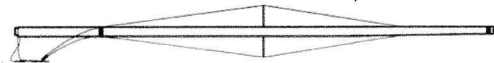

DATE MEASURED 11-Mar.-2021 MEASURER'S STAMP

**04** SCIRA  
 MEASURER  
 JAPAN

MEASURER'S NAME Kuniko Yamada

NOTES: