

# SNIFE CLASS RACING ASSOCIATION

## MEASUREMENT DATA SHEET FOR CERTIFIED BOATS

Revised February 2019

*This page to be used for all boats. For measurements in Italic refer to the Class Rules*

HULL NUMBER 31775 BUILDER Person Marine Japan  
 MODEL NINJA II YEAR OF MANUFACTURE 2022  
 OWNER MEIKAI UNIV. COUNTRY Japan

BARE HULL  COMPLETE  INCOMPLETE   
 HULL MATERIAL: WOOD  FIBERGLASS  make note of  
 DECK MATERIAL: WOOD  FIBERGLASS  incomplete items  
 FROM CERTIFIED MOULD  filling the cells with **NO**

|  |              |                                      |                                     |
|--|--------------|--------------------------------------|-------------------------------------|
| HULL WEIGHT (min 125kg)                | <u>125.3</u> | MAST LENGTH (Rules C.9.2, F.3.4)     | <u>6499</u>                         |
| TOTAL WEIGHT (min 172.8kg)             | <u>172.8</u> | Limiting marks & pin                 | <input checked="" type="checkbox"/> |
| CORRECTOR WEIGHTS (max 15kg)           | <u>7.92</u>  | Corrector weights (max 100gr)        | <input checked="" type="checkbox"/> |
| MOI                                    | <u>276</u>   | BOOM LENGTH (max 2642mm)             | <u>2640</u>                         |
| Spring set #                           | <u>#90</u>   | Limiting marks & pin                 | <input checked="" type="checkbox"/> |
| JIB FITTING                            | <u>288</u>   | POLE LENGTH (max 2642mm)             | <u>2638</u>                         |
| (279-330mm hor. From Hull Datum Point) |              | RUDDER DIMENSIONS                    | <input checked="" type="checkbox"/> |
| max 45mm vert. above sheerline)        |              | Weight (min. 2.72kg)                 | <u>2.76</u>                         |
| SHROUDS (1778-1981mm from HDP)         | <u>1782</u>  | Corrector weights (Rule C.8.5)       | <u>0</u>                            |
| MAST HOLE (min 1494-mm from HDP)       | <u>1494</u>  | Parallel to transom (tolerance 2mm)  | <input checked="" type="checkbox"/> |
| UPPER GUDGEON (Rule D.2.3)             | <u>410</u>   | DAGGERBOARD DIMENSIONS               | <input checked="" type="checkbox"/> |
| LOWER GUDGEON (Rule D.2.3)             | <u>155</u>   | Band                                 | <input checked="" type="checkbox"/> |
| GUDGEONS DIAMETER (Rule D.2.3)         | <u>8</u>     | Safety line (max 610mm long)         | <input checked="" type="checkbox"/> |
|  |              | Restraining system (hooks or tablet) | <input checked="" type="checkbox"/> |

Insert the **actual** measurement in the cells marked as

Mark corrector weights position and amount below. Data to be copied on the Official Snipe Label

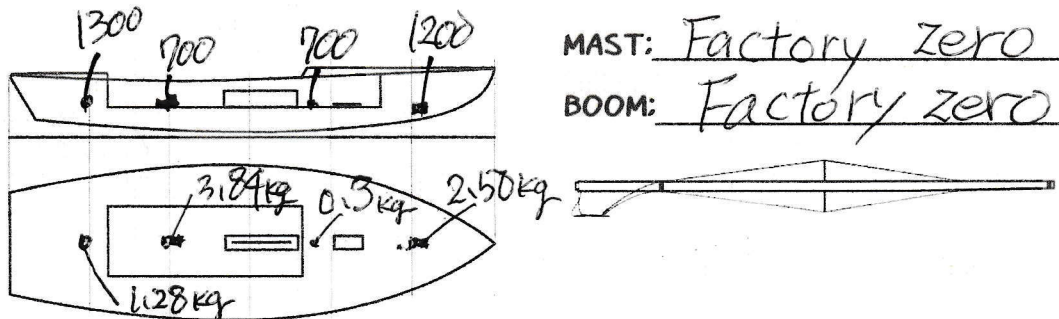

DATE MEASURED 13-May-2022 MEASURER'S STAMP

MEASURER'S NAME Kuniko Yamada  
 NOTES:

**04** SCIRA  
 MEASURER  
 JAPAN