

SNIFE CLASS RACING ASSOCIATION

MEASUREMENT DATA SHEET FOR CERTIFIED BOATS

Revised February 2019

This page to be used for all boats. *For measurements in Italic refer to the Class Rules*

HULL NUMBER	31913	BUILDER	TSUTSUDO RACING
MODEL	TRC-1	YEAR OF MANUFACTURE	2024
OWNER	Motoharu Nishii	COUNTRY	Japan

BARE HULL	<input type="checkbox"/>	COMPLETE	<input checked="" type="checkbox"/>	INCOMPLETE	<input type="checkbox"/>
HULL MATERIAL: WOOD	<input type="checkbox"/>	FIBERGLASS	<input checked="" type="checkbox"/>	make note of	
DECK MATERIAL: WOOD	<input type="checkbox"/>	FIBERGLASS	<input checked="" type="checkbox"/>	incomplete items	
FROM CERTIFIED MOULD	<input type="checkbox"/>			filling the cells with NO	

HULL WEIGHT (min 125kg)	127.6	MAST LENGTH (Rules C.9.2, F.3.4)	6.99
TOTAL WEIGHT (min 172.8kg)	112.84	Limiting marks & pin	<input checked="" type="checkbox"/>
CORRECTOR WEIGHTS (max 15kg)	7.0	Corrector weights (max 100gr)	<input checked="" type="checkbox"/>
MOI	271	BOOM LENGTH (max 2642mm)	2641
Spring set #	#95	Limiting marks & pin	<input checked="" type="checkbox"/>
JIB FITTING	281	POLE LENGTH (max 2642mm)	2641
(279-330mm hor. From Hull Datum Point)		RUDDER DIMENSIONS	<input checked="" type="checkbox"/>
max 45mm vert. above sheerline)		Weight (min. 2.72kg)	2.72
SHROUDS (1778-1981mm from HDP)	1781	Corrector weights (Rule C.8.5)	0
MAST HOLE (min 1494-mm from HDP)	1495	Parallel to transom (tolerance 2mm)	<input checked="" type="checkbox"/>
UPPER GUDGEON (Rule D.2.3)	41	DAGGERBOARD DIMENSIONS	<input checked="" type="checkbox"/>
LOWER GUDGEON (Rule D.2.3)	156	Band	<input checked="" type="checkbox"/>
GUDGEONS DIAMETER (Rule D.2.3)	8	Safety line (max 610mm long)	<input checked="" type="checkbox"/>
		Restraining system (hooks or tablet)	<input checked="" type="checkbox"/>

Insert the **actual** measurement in the cells marked as

Mark corrector weights position and amount below. Data to be copied on the Official Snipe Label

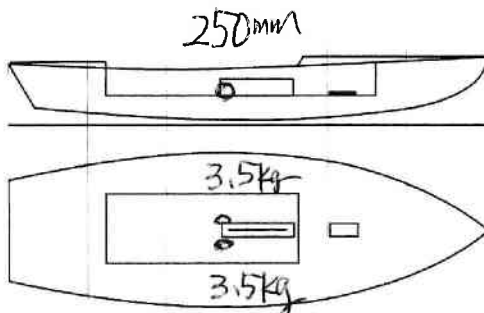

Mast SELDEN
Boom Factory zero



DATE MEASURED 6-Mar.-2024 MEASURER'S STAMP

MEASURER'S NAME Kuniko Yamach

NOTES:

04 SCIRA
MEASURER
JAPAN